

Chasing Chaos with an RL-Diode Circuit

Junaid Alam and Sabieh Anwar
LUMS School of Science and Engineering

Wednesday, March 24, 2010

Have you ever wondered how science can be so organized and streamlined and yet be able to explain almost everything that we encounter? The answer to this genius skepticism is quite straightforward: we made it simple, for it was meant to simplify and systematize what seemed to be erratic and complicated. Science is a step towards intellectual sophistication in order to make things simple and explicable. This is what Leonardo da Vinci says, “simplicity is the ultimate sophistication.”

In this experiment, on the contrary, we are going to shun the struggle for simplicity. Instead we are going to look into the complicated side of matters—those that appear to be simple. Let us forget for the time being that simplicity is what we are after; let’s pursue complexity and intrigue; let’s chase *Chaos*.

KEYWORDS

Dynamical System · Supersensitivity · Phase Portrait · Poincare Map · Attractor · Fractals · Self-similarity · Feigenbaum Constant · Recovery Time · Junction Capacitance · Resonance · Period Doubling Bifurcation · Chaos.

APPROXIMATE PERFORMANCE TIME 1 week.

1 Objectives

In this experiment, we will discover:

1. how very simple systems can exhibit complex behavior under certain conditions,
2. the richness of the mathematical and physical structure of dynamical systems,
3. how an arbitrarily small change in the input can change the long-term conduct of a dynamical system drastically,
4. why the notion of stability and performance can be even crucial in design of dynamical systems,
5. how to construct and interpret phase portraits and Poincare Maps for different kinds of responses of a system,

6. the mystery of Feigenbaum constant and what makes chaos a universal underlying structure of the complexity exhibited by nonlinear dynamical systems,
7. a beautiful and artistic aspect of science in the form of attractors and fractals.

References

- [1] Gregory L. Baker, J. P. Gollub, “Chaotic dynamics: an introduction”, 2nd Edition, Melbourne: Cambridge University Press, 1996, Ch. 1-4.
- [2] Robert C. Hilborn, “Chaos and Non-Linear Dynamics: An Introduction for Scientists and Engineers”, 2nd Edition, New York: Oxford University Press, 2000, Ch. 1-4.
- [3] J. Testa, J Perez and C. Jefferies, “Evidence for Universal Chaotic Behavior of a Driven oscillator”, *Phys. Rev. Lett.*, Vol. 48, pp. 714-717, 1982.
- [4] R.W. Rollins and E. R. Hunt, “Exactly Solvable Model of a Physical System Exhibiting Universal Chaotic Behavior”, *Phys. Rev. Lett.*, vol. 49, pp. 1295-1298, 1982.
- [5] A. Azzouz, R. Duhr and M. Hasler, “Transition to Chaos in a Simple Nonlinear Circuit Driven by a Sinusoidal Voltage Source”, *IEEE Trans. Circuits Syst.*, Vol. CAS-30 (12), 1983.
- [6] M. P. Haniyas, Z. Avgerinos, G.S. Tombras, “Period Doubling, Feigenbaum constant and time series prediction in an experimental chaotic RLD circuit”, *Chaos, Solitons and Fractals* 40 (2009); 1050-1059.
- [7] A.B. Ozer, E. Akin, “Tools for Detecting Chaos”, *SA Fen Bilimleri Enstitüsü Dergisi* 9. Cilt, 1. Sayı 2005.
- [8] N. C. Ropes, “Poincare Sections and the R-L-Diode Circuit”, 28th Southeastern Symposium on System Theory (SSST), 1996.

2 Foundations

Summon up: What kind of nonlinear phenomena have you come across? Try to list a few, with a reason to why you believe them to be nonlinear.

Ponder: Is it that all the linear processes that you have ever known about, are really linear? Remember one, and put it to test.

Mathematical linearization of scientific problems for the sake of practicality has been, in fact, a human confession that indicates a mere discrepancy regarding our reach and grasp over nature. It would be naive to think that linearization works very often. We can hardly find linear processes in nature. The spirit of nature is indeed non-linear. On the other hand, no wonder, dynamical systems, systems having different behavior at different instants of time, comprise the core of scientific study. Therefore, in physics, nonlinear dynamical systems remain a vitally important subject. Our current experiment is about one such system.

2.1 Defining Nonlinear Dynamics

Nonlinear dynamics, is the field of physics and mathematics that deals with the most common kind of natural systems, systems that keep changing with time and are nonlinear. Being a bit more technical, dynamical systems for which the principle of superposition doesn't hold are termed as nonlinear. For such systems the sum of responses to several inputs cannot be treated as a single response to the sum of those all inputs. Qualitatively speaking [2]:

A nonlinear system is a system whose time evolution equations are nonlinear; that is, the dynamical variables describing the properties of the system (for example, position, velocity, acceleration, pressure, etc.) appear in the equation in a nonlinear form.

Now, if x represents an input variable and y is the output as a function of x , **the principle of superposition** in its very simplistic form states that:

$$y(x_1 + x_2 + \dots + x_n) = y(x_1) + y(x_2) + \dots + y(x_n) \quad (1)$$

The above mathematical expression means that if the stimulus to a linear system is doubled, the response is also doubled. For a nonlinear system, the response will be greater or less than that.

Ask yourself: Could it be that a system is both linear and nonlinear at the same time? Can a system be linear for some conditions and nonlinear for others?

2.2 Nonlinearity: A Conduit to Chaos

What makes this nonlinearity so important? The basic idea is that for a linear system, when a parameter (e.g. the spring constant k in a spring mass system) is varied, it doesn't change the *qualitative* behavior of the system. On the other hand, for nonlinear systems, a small change in a parameter can lead to sudden and dramatic changes in both the qualitative and quantitative behavior of the system. For one value, the behavior might be periodic. For another value only slightly different from the first, the behavior might be completely aperiodic.

Contemplate: What could be a physical explanation of this unpredictability and sudden change in behavior?

2.2.1 Chaos defined

In the context of nonlinear dynamical systems, chaos is a word used to describe the time behavior of a system that is aperiodic, and is *apparently* random or “noisy”. But, underlying this chaotic randomness is an order that can be determined, in some sense, by the very time evolution equations that describe the system. Even when it may sound paradoxical, such an apparently random system is in fact deterministic.

Understand: What can you comprehend from the statement “such an apparently *random* system is in fact *deterministic*”? What is meant by such determinism?

2.2.2 Origins of chaos

Now, let us briefly try to answer the question: what could be the origin of chaos in nonlinear systems? Chaotic behavior shows up in systems that are essentially free from noise and are also relatively simple, *i.e.* possess only a few degrees of freedom. This tells us that chaotic behavior actually depends on the physical aspects and the spatiotemporal properties of a nonlinear system.

2.3 Chaos ringing the door-bell

Usually, chaotic behavior doesn't appear without informing us when it is about to come, adding to the beauty of this brave and organized disorder. Generally, it all starts with a so called *period-doubling bifurcation*: system switches to a new behavior with twice the period of the original system at a particular value of a certain parameter. As the value of that parameter is further increased, successive bifurcations occur and the behavior of system takes a time period that is four times, then eight times and so on, finally ending in chaotic behavior. This makes the story of chaos eventful and, as we shall see later, universal.

The math ingredient: A dynamical system is expressed by its differential equations. What happens to the solution of the system equations when a bifurcation occurs?

3 Identifying Chaos

We need to recognize chaos by face, for we are going to encounter it several times in our experiment. So, now we will learn about some useful tools that can help us identify chaos.

3.1 Time series

The very first and basic tool is the time series. Knowing the fact that chaos implies aperiodicity, we can tell if the system is chaotic by investigating the “shape” of its time series.

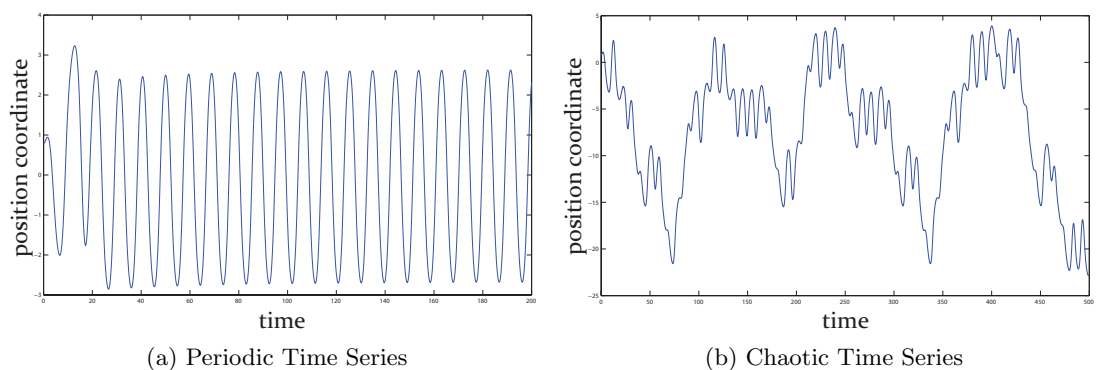

Figure 1: Time-series for periodic and chaotic behavior

But not all of the aperiodic responses imply chaos; many signals might be aperiodic due to the statistical noise or the complexity of the system. Therefore, time series analysis should be carried out for several initial conditions that may in turn validate the presence of chaos by exhibiting “divergence of nearby trajectories”, i.e. difference in subsequent trajectories for slightly different initial conditions.

3.2 Fourier spectrum

From our discussion about the time series of a chaotic system, we may surmise that like any aperiodic response, the response of a chaotic system will have a continuum of frequencies when seen in the Fourier domain. This is indeed the case, and is a very useful tool to recognize chaos.

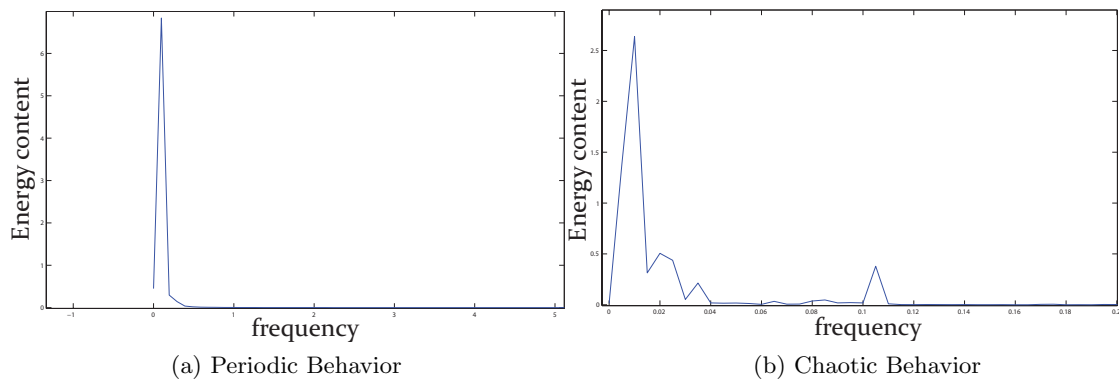

Figure 2: Fourier spectra of periodic and chaotic behavior

Still one should not forget that Fourier spectrum of a completely random response is also a continuum of frequencies, so, this tool is useful when system approaches chaos after passing through several bifurcations and we can, in some way, track them.

Exploit: When you know what chaos looks like, can you come up with a scheme to harness chaos and put it to practical use?

3.3 Phase portraits

The notion of state space (or phase space) is a very rich topic. It has a venerable history of being helpful in stability analysis as well as quantitative inspection of dynamical systems. The basic idea in using a state space model is that if we are provided with the knowledge of the state variables, the variables that represent the state of a system, for a particular scenario and the rate of change of those state variables, we can predict the behavior of the system in terms of those variables at any time. This leads to the idea of using conjugate variables (Fourier duals of each other, or the position and momentum variables of the system) as the canonical coordinates for a state space representation. So, for a periodic system that obeys the law of energy conservation (e.g. a pendulum), the state space plot (phase portrait) will be one closed loop for a particular set of initial conditions. For a chaotic system, there will be many distinct loops in a phase portrait, showing that the system is aperiodic and does not approach a stable trajectory.

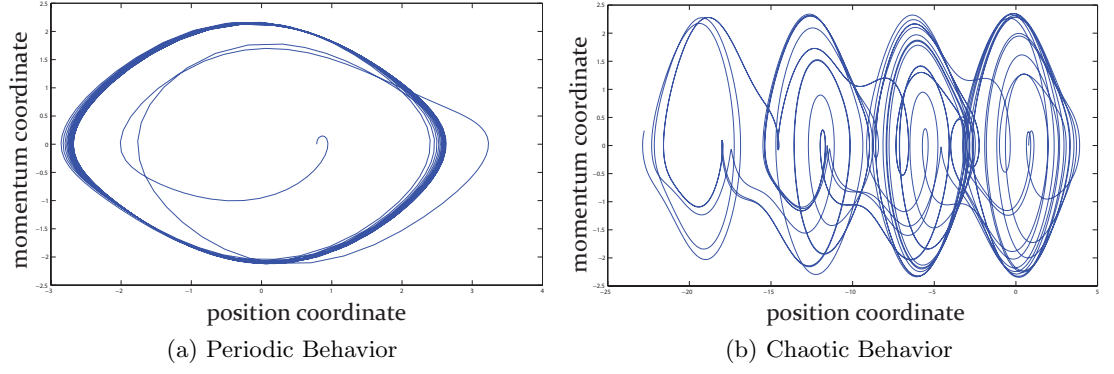

Figure 3: Possible phase portraits of periodic and chaotic behavior. Refer to main text for labelling of axis

3.3.1 Example of a simple pendulum

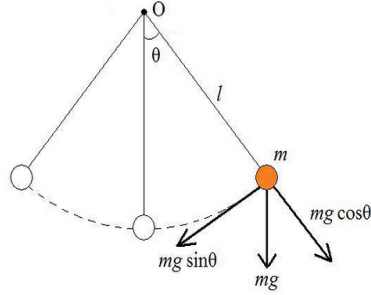

Figure 4: The simple pendulum

Consider a simple pendulum having a small amplitude of oscillation (so that we can assume $\sin \theta \approx \theta$). Ignoring friction, it may be represented using Newton's second law by a normalized second order differential equation of the form:

$$\frac{d^2\theta}{dt^2} + \frac{g}{l}\theta = 0 \quad (2)$$

where θ represents the angular position of the pendulum. The solution of this equation will be:

$$\theta = \theta_o \sin(\omega t + \phi) \quad (3)$$

where θ_o is the maximum angular displacement. The first derivative of θ is:

$$\dot{\theta} = \theta_o \omega \cos(\omega t + \phi) \quad (4)$$

Now, from (3) and (4), writing an equation in terms of θ and $\dot{\theta}$ will give the parametric equation:

$$\frac{\theta^2}{\theta_o^2} + \frac{(\dot{\theta})^2}{(\omega\theta_o)^2} = 1 \quad (5)$$

which is evidently the equation of an ellipse with θ on the horizontal and $\dot{\theta}$ on the vertical axis and represents a periodic trajectory in the phase space. In this context, θ and $\dot{\theta}$ represent the canonical coordinates. Using the two coordinates, we can find the state of the system at any instant.

Implicate: Write down the equation of energy of a pendulum in terms of position and momentum variables indicated in the formalism above. What is the total energy in the system?

Figure out: What does a closed loop in phase space signify? What can we say about the energy contained in a system?

A step ahead: Draw the circuit diagram of an RLC circuit. Write down the differential equation of the system and identify the canonical coordinates.

3.4 Poincare sections

Another very useful way of analyzing the behavior of a nonlinear dynamical system is a Poincare Section or Poincare Map. The basic motivation behind making such a map is to reduce an n -dimensional system to an $(n - 1)$ -dimensional system, making the analysis easier and a bit more intuitive.

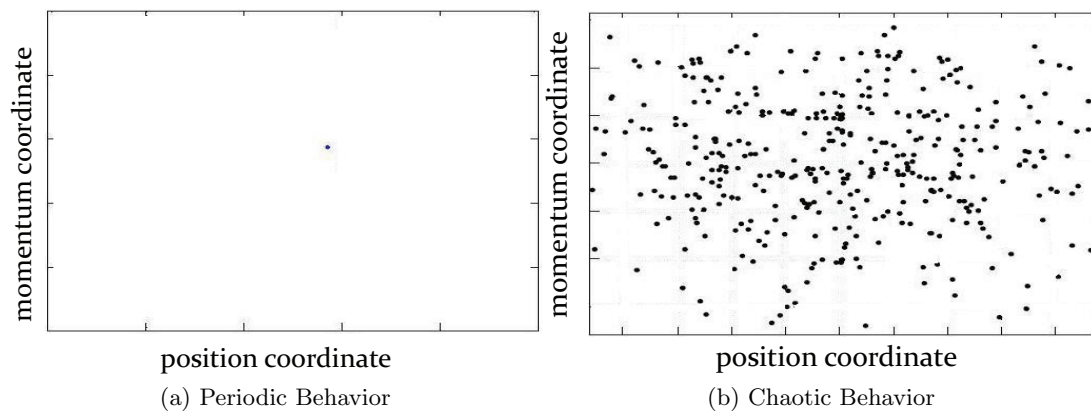

Figure 5: Poincare sections for periodic and chaotic behavior

Constructing a Poincare map is simple: sample the phase portrait of the system stroboscopically [7].

For periodic behavior, Poincare map will be a single point. For chaotic or aperiodic behavior, there will be many irregularly distributed points in the map.

Iterate: In a Poincare map, why is there a single point for periodic and a scatter of points for aperiodic behavior? Can you construct phase space trajectories from a given Poincare section?

3.5 Bifurcation diagram

A very beautiful way of expressing the behavior of a dynamical system over the entire range of a particular parameter is the bifurcation diagram.

It shows a correspondence between the parameter values and the resulting response of the system. Every bifurcation indicates a successive period doubling and the response branches off into two. In figure (6), as the control parameter λ is varied over a certain range, the response x_n takes different number of values: two values at the first bifurcation,

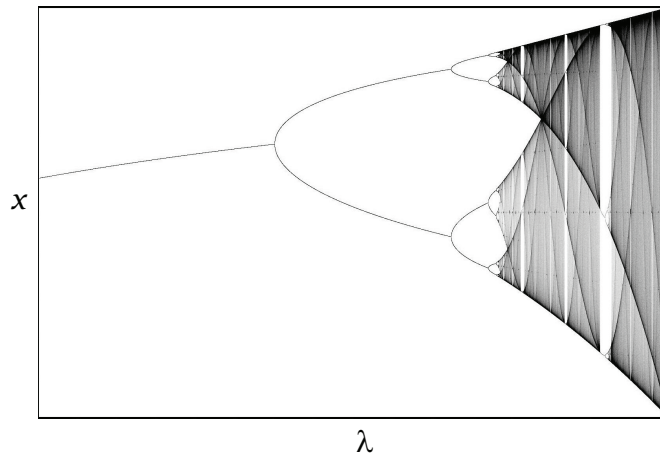

Figure 6: Bifurcation diagram. (source: wikipedia.org)

four values at the second bifurcation, eight values at the third bifurcation and so on. The fuzzy bands indicate chaotic behavior. Also, one can observe the periodic bands within the chaotic ones, showing that chaos can suddenly vanish and give rise to certain higher order periods. This is mainly because of the fact that differential equations defining the system may abruptly switch from chaos to a definite set of solutions for a certain value of the control parameter.

Identify: What does the presence of dark contours within the chaotic bands of the bifurcation diagram indicate?

3.6 Universality of chaos

As we have already signaled, chaos is not a mere state of unpredictability and disorder. It also enjoys the repute of a deterministic and universal framework that makes the canvas of this subject even multihued. The interesting thing to notice is that the same kind of mathematical description is quite germane to entirely different classes of systems: from control systems and lasers to climatology and chemical reactions. Let us just briefly touch few of its most amazing qualitative and quantitative aspects.

3.6.1 Feigenbaum constant

When we look at a bifurcation diagram, such as the one shown in figure (6), we can see the distances between successive bifurcations getting smaller and smaller in a geometric way (along the horizontal axis). This is what Feigenbaum noticed: *the ratio of differences of parameter values at which successive bifurcations occur is the same for all the splittings* [2]. Mathematically speaking:

$$\delta_n = \frac{\lambda_n - \lambda_{n-1}}{\lambda_{n+1} - \lambda_n} \quad (6)$$

where λ_n is the parameter value at which the n th bifurcation occurs. Moreover, this

ratio converges to a particular value—called the Feigenbaum constant—as n approaches infinity:

$$\delta \equiv \lim_{n \rightarrow \infty} \delta_n = 4.669201 \dots \quad (7)$$

This constant indicates a very universal and a quantitative equivalence between apparently very different physical systems.

A step ahead: Observe the diagram in figure (6) closely. Can you find out a similar constant for *vertical* spacings between successive branches each time they bifurcate?

3.6.2 Attractors and fractals

An important manifestation of the fact that chaos is deterministic are *attractors*: a set of points (or trajectories) to which all other trajectories—that start from the initial conditions lying within a region called the *basin of attraction*—approach, as the time goes to infinity. Looking at the accompanying figure, we can observe how trajectories remain within a certain region of state-space. This *confinement* of trajectories within a certain region for a particular set of initial conditions is what points toward the determinism in the chaotic behavior.

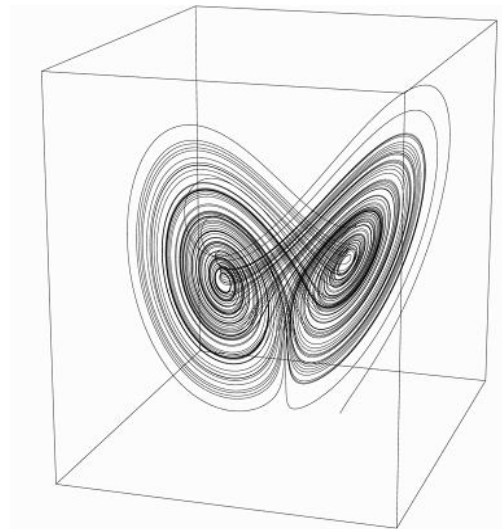
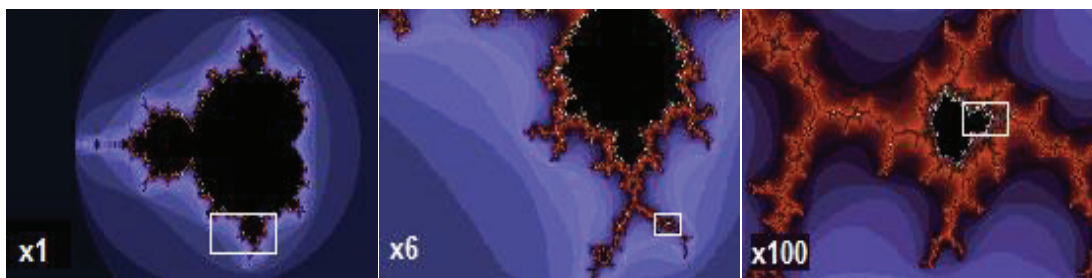

Figure 7: The Lorenz attractor: state-space trajectories are confined

Attractors, in addition to their aesthetic appeal and tendency to provide us with information about the active degrees of freedom in a system, also determine the dynamical properties of the system’s long-term behavior.



(a) Mandelbrot Fractal

(b) Magnified x6

(c) Magnified x100

Figure 8: Mandelbrot fractal: regions indicated in boxes are magnified. A resemblance with unscaled image can be noticed even when magnified 100 times

The discussion on attractors cannot go without mentioning one of the most aesthetically rich notions in mathematics, namely fractals, that actually link attractors with the

universality of chaos. Fractals are self similar and self replicating geometrical structures (figure (8)) that occur in the state space as attractors with a *noninteger dimension* and are sometimes called *strange attractors*. Noninteger dimension refers to the idea that, in general, these geometrical figures do not have a point, axis or plane of symmetry, and yet they are self-similar within themselves: they look the same at any degree of magnification. This is another characteristic beauty of chaos.

Be intuitive: Can you establish a connection between self-similarity of fractals and the universality of chaos as exhibited through Feigenbaum constant?

The genius hunch: What is the possible relationship between entropy and chaos?

4 The Experiment

A simple RL-Diode circuit is going to be the subject of this experiment. Although it is a simple system, it exhibits interesting behavior including bifurcations and chaos. A series arrangement will be used as shown in the figure below.

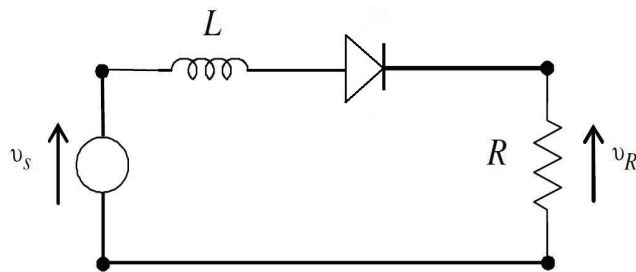

Figure 9: The Experimental RL-Diode circuit [6].

4.1 The Circuit

The circuit (figure (9)) will behave in two different modes: first when the diode is forward biased, the other when it is reverse biased.

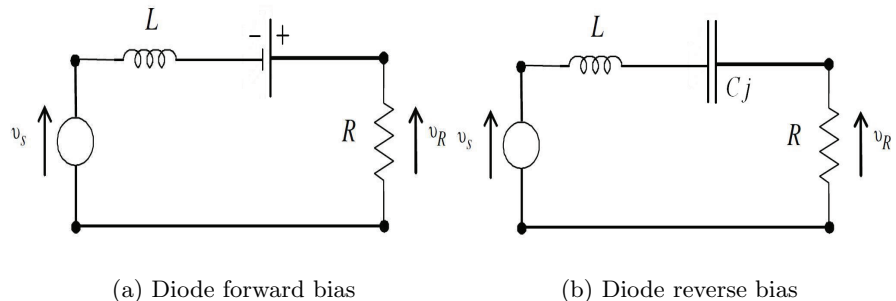

Figure 10: Equivalent circuits for forward and reverse bias cycle.

4.2 The Mathematical Model

During the conducting cycle, the circuit reduces to what is shown in figure (10a), with the diode acting as a fixed bias. The KVL expression turns out to be a first order differential equation, given as:

$$L \frac{dI}{dt} + RI = V_o \sin \omega t + V_f \quad (8)$$

where V_o is the peak amplitude of the AC input voltage and V_f is diode forward voltage drop. The solution of this equation, i.e. the current in the conducting cycle can be easily found out to be [4]:

$$I(t; A) = \left(\frac{V_o}{Z_a}\right) \cos(\omega t - \theta) + \frac{V_f}{R} + Ae^{-Rt/L} \quad (9)$$

In equation (9), θ represents the power factor angle or phase delay, given as: $\theta = \tan^{-1}(L/R)$, A is a constant of integration to be calculated using the initial conditions and Z_a is the forward bias impedance of the circuit and is equal to $\sqrt{R^2 + \omega^2 L^2}$.

In the non-conducting cycle, the diode behaves as a capacitor having a capacitance equal to its junction capacitance (C_j). The equivalent circuit can be represented as a driven RLC circuit (figure (10b)). The loop equation for KVL will become a second order differential equation of the form:

$$L \frac{d^2 I}{dt^2} + R \frac{dI}{dt} + \left(\frac{1}{C_j}\right)I = V_o \omega \sin \omega t \quad (10)$$

Equation (10) can be solved using the traditional two step technique of solving a non-homogeneous differential equation, i.e. separately for particular and homogeneous solutions.

Derive: Derive the solution of equation (10).

The final solution of equation (10) can be written as [4]:

$$I(t; B, \phi) = \left(\frac{V_o}{Z_b}\right) \cos(\omega t - \theta_b) + Be^{-2Rt/L} \cos(\omega_b t - \phi) \quad (11)$$

The constants B and ϕ are the constants of integration and can be found using the initial conditions of the cycle. Moreover, θ_b is the phasor angle of the RLC network given as $\theta_b = \tan^{-1}(L(\omega^2 - \omega_o^2)/R)$, $\omega_o^2 = (1/LC_j)$ and $\omega_b^2 = \omega_o^2 - (R/2L)^2$.

Exercise: Instead of a piece-wise mathematical description, can you represent the circuit with a generalized differential equation?

4.3 The Physical Model

4.3.1 The diode recovery-time

Prior to looking into the practical behavior of the circuit and how it becomes chaotic, we need to understand the meanings and significance of an important parameter: the diode's recovery time. The recovery time of a diode is the time a diode would take to completely stop the flow of current through itself as it moves into the non-conducting cycle. It depends on the amount of forward current that flows through the diode. The greater the peak forward current, the longer the diode recovery time. Quantitatively speaking [4]:

$$\tau_r = \tau_m [1 - \exp(-|I_m|/I_c)] \quad (12)$$

where $|I_m|$ is the magnitude of the most recent maximum forward current, and τ_m and I_c are fabrication parameters for the specific diode.

Bring to Light: What can be a physical explanation of a diode's junction capacitance? What relationship does it have with the recovery time?

4.3.2 Route to Chaos

When the circuit is operated at the resonant frequency, a certain amount of reverse current will flow through the diode in every reverse bias cycle due to the finite recovery time of the diode. If the peak current $|I_m|$ is large in the conducting cycle (figure (11), interval 'a'), the diode will switch off with a certain delay (figure (11), interval 'b') due to the finite recovery time and so will allow a current to flow even in the reverse-bias cycle. This reverse current, in turn, will prevent the diode from instantly switching on in the forward bias cycle; it will turn *on* with a delay (figure (11), interval 'c'). This will keep the forward peak current smaller than in the previous forward bias cycle, hence giving birth to two distinct peaks of the forward current. Notice that it took *two* cycles of the driving signal in this process. This is what we identify as a period-doubling bifurcation.

When the peak value of input is increased further, bifurcation to period-4 occurs, followed by higher bifurcations and eventually chaos. Figure 11 shows a period doubling scenario.

Self-Assessment: Briefly explain figure (11) according to the labels on the time axis, describing what happens at every marked instant.

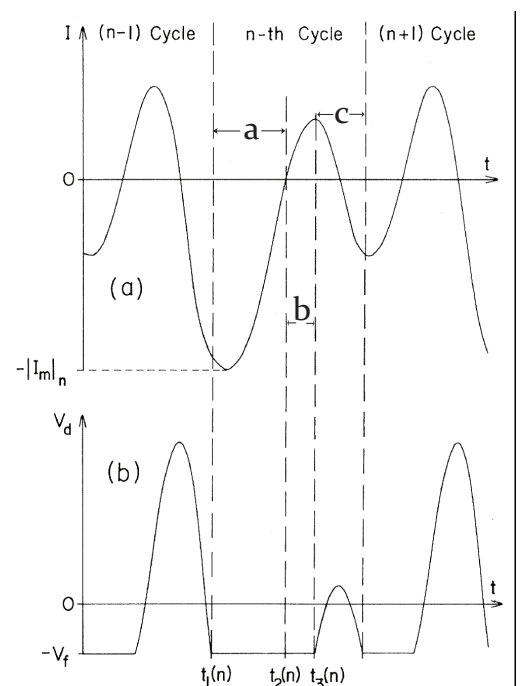

Figure 11: Circuit Current and Diode Voltage (period-2). Diode conducts when $V_d = -V_f$

4.4 The Task

4.4.1 The Setup

You will need a very simple and familiar set of components to deal with this experiment. The list of components is listed here.

1. Oscilloscope
2. Function Generator
3. Data Acquisition Setup
4. Bread Board
5. Circuit components

4.4.2 The Procedure

Now it is the time to start our experimental expedition, following the step-by-step procedure:

1. Connect the components on the bread-board according to the circuit diagram.
 2. Excite the circuit with a sinusoidal AC signal of minimum possible amplitude and a low frequency.
 3. Observe the output of the circuit using the oscilloscope to find the resonant frequency of the circuit and the junction capacitance of diode.
 4. Start increasing the amplitude gradually and observe the change in the time series plot of the output voltage. Note down the amplitude of the input at which the first bifurcation occurs.
 5. Increasing the amplitude further, also observe and note down the input voltage amplitude at which higher bifurcations occur until chaos jumps in.
 6. Repeat the measurements several times and calculate an average value of Feigenbaum constant from your data. Also observe the bifurcations while decreasing the input amplitude and hence find if there is any hysteresis.
- Expose:** What could be the possible reasons of hysteresis in this specific context?
7. By using the oscilloscope in the XY mode, identify period-doublings and calculate again the value of Feigenbaum constant.
 8. Observe the Chaotic behavior in the XY plots and try to explain why chaos must have a fuzzy display.

Ask Yourself: Can you make a connection between the XY plots and the phase portraits?

Observe: Even in the chaotic behavior, there are several darker loops visible in the XY plots of scope. What can you tell about them?

9. Now, turn on the Computer, login and run the file RLD-DAQ.vi located on your desktop.
10. By copying the data generated by LabVIEW into MATLAB, plot the phase portrait for the circuit data obtained for periodic as well as chaotic regimes.
11. Using the known sampling frequency and the input frequency, plot the Poincare map for the circuit output data for several periodic and chaotic responses.
12. Using MATLAB, plot the Fourier spectrum for different kinds of behavior.
13. Repeat the procedure for output with different periods as well as for chaotic behavior.

Ponder: What do the peaks in the Fourier spectrum indicate? Why are there peaks even in the spectrum of chaotic output?

Follow the Agents: What are the characteristics of this particular circuit that make it exhibit chaos? Can you have several physical explanations?