



LDTTC2/2

Combine the drive power of the WLD3343 with the temperature stability of the WTC3243

GENERAL DESCRIPTION:

The LDTTC 2/2 combines a 2.2 Amp laser driver and 2.2 Amp temperature controller on one small board. Available as an open frame or in a chassis mount enclosure.

The WTC3243 will control temperature using thermistors, RTDs, or linear temperature sensors such as the LM335 or the AD590. Adjust temperature using the onboard trimpot or a remote voltage input from a panel mount potentiometer, DAC, or other voltage source. A default temperature setpoint configuration provides fault tolerance and avoids accidental damage to system components. Adjustable trimpots configure heat and cool current limits.

The heart of the laser driver section is the WLD3343 2.2 Amp Laser Driver. It maintains precision laser diode current (Constant Current mode) or stable photodiode current (Constant Power mode) using electronics compatible with A/B Type lasers.

Ideal for integrated laser driver or LED packages that include temperature control, often utilized in medical diagnostic equipment, remote sensing, analytical instrumentation, military and communications applications.



FEATURES, LDTTC2/2:

- Small package size
- Single supply operation possible
- Cost Effective

FEATURES, Laser Diode Driver:

- Default current range is 2.2 A. Custom ranges, from 3 mA up, are easily configured
- Slow start laser diode protection
- Constant Current or Constant Power modes
- Compatible with A or B type laser diodes
- Adjustable laser diode current limit
- Remote TTL Shutdown / Interlock

FEATURES, Temperature Controller:

- Drive up to 2.2 A of TEC current
- Set temp using D/A - includes default to 1 Volt to avoid drive when D/A is turned off or signal is lost
- Ultra-stable PI control loop
- Separate Heat & Cool current limits
- Single power supply operation possible

Figure 1

Top View Pin Layout and Descriptions

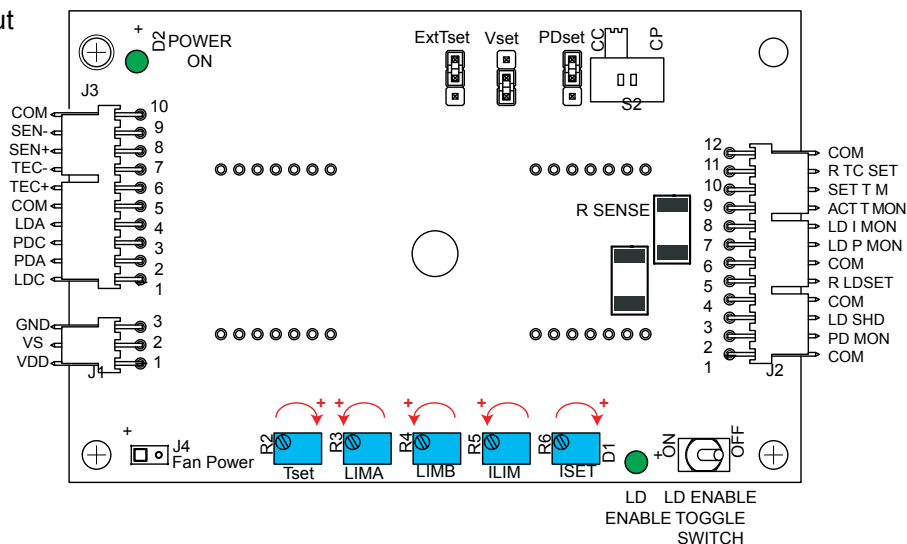

QUICK CONNECT DIAGRAM

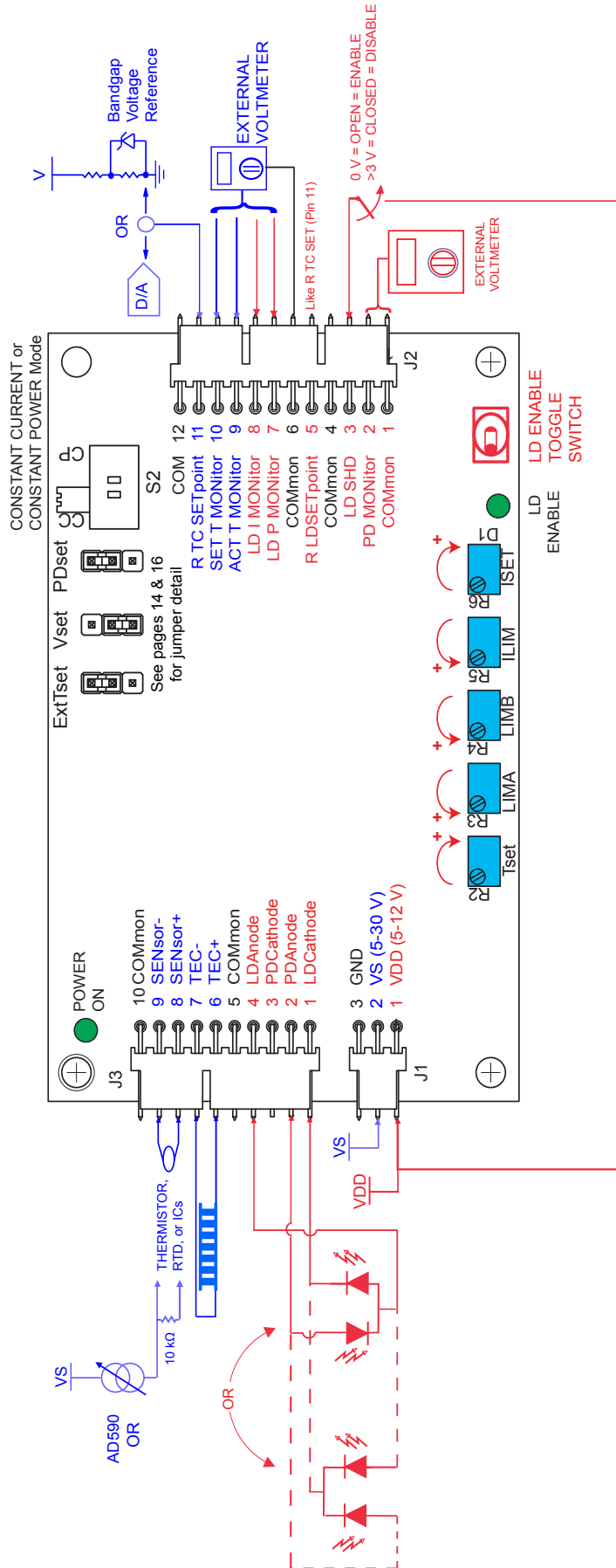

V_{DD} and V_S can be tied together if common voltage provides sufficient compliance for laser diode and thermoelectric loads. Separate V_S if higher compliance is required.

BLOCK DIAGRAM Schematic for WLD3343 Connections

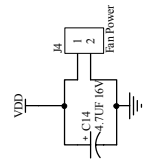
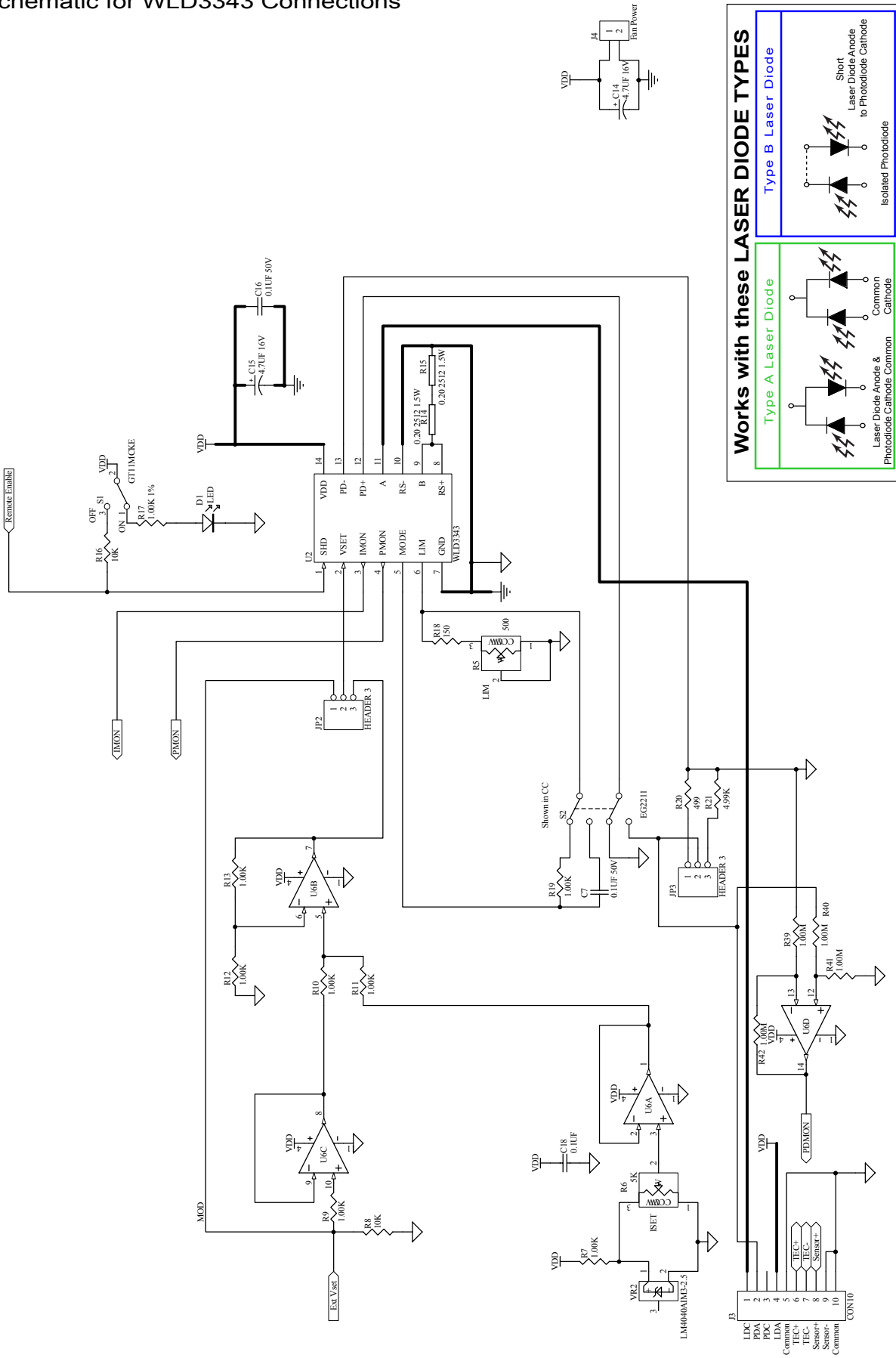

Works with these LASER DIODE TYPES

Type A Laser Diode

Laser Diode Anode & Photodiode Cathode Common

Type B Laser Diode

Short Laser Diode Anode to Photodiode Cathode

BLOCK DIAGRAM
Schematic for WTC3243 Connections

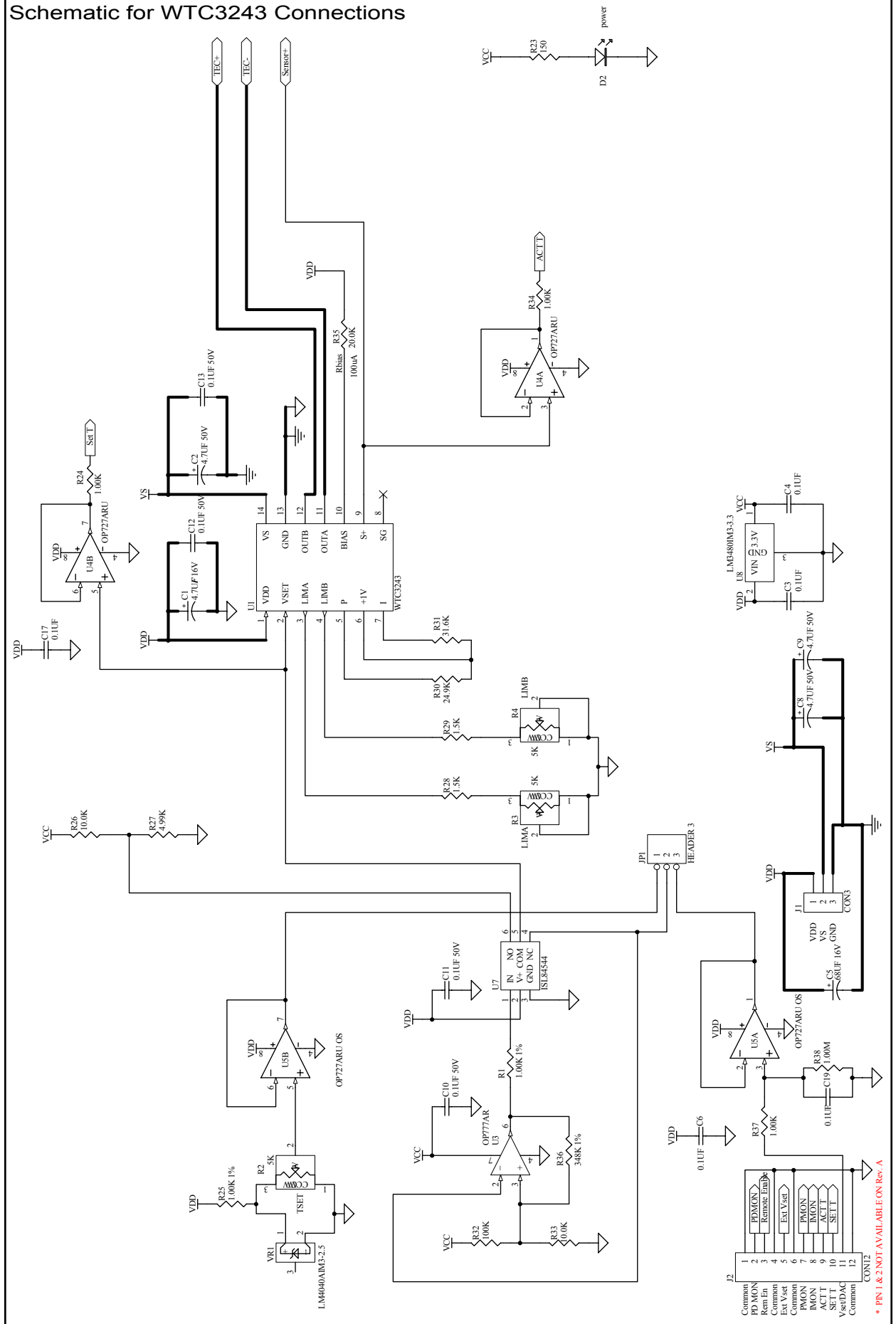

ABSOLUTE MAXIMUM RATINGS				SYMBOL	VALUE	UNIT
Operating Temperature, case [1]				T _{OPR}	- 40 to + 85	°C
Storage Temperature				T _{STG}	- 65 to +150	°C
Weight - with enclosure				LDTC2/2E	6.5	oz
Weight - open frame				LDTC2/2O	2.4	oz
WLD3343 Laser Diode Driver Rating				SYMBOL	VALUE	UNIT
Supply Voltage (Voltage on Pin 14)				V _{DD}	+4.75 to +12	Volts DC
Output Current (See SOA Chart)				I _{LD}	2.2	Amps
Power Dissipation, T _{AMBIENT} = +25°C				P _{MAX}	9	Watts
WTC3243 Temperature Controller Rating				SYMBOL	VALUE	UNIT
Supply Voltage 1 (Voltage on Pin 1)				V _{DD}	+4.75 to +12	Volts DC
Supply Voltage 2 (Voltage on Pin 14)				V _S	+4.5 to +28	Volts DC
Output Current (See SOA Chart)				I _{OUT}	±2.2	Amps
Power Dissipation, T _{AMBIENT} = +25°C (with fan and heat sink per SOA Chart)				P _{MAX}	9	Watts
Laser Diode Driver PARAMETER	TEST CONDITIONS	MIN	TYP	MAX	UNITS	
CONSTANT CURRENT CONTROL						
Long Term Stability, 24 hours	T _{AMBIENT} = 25°C		50	75	ppm	
CONSTANT POWER CONTROL						
Long Term Stability, 24 hours	T _{AMBIENT} = 25°C	0.02		0.05	%	
Short Term Stability, 1 hour	T _{AMBIENT} = 25°C		0.01		%	
OUTPUT						
Current, peak, see SOA chart	With Heat Sink and Fan	1.8	2.0	2.2	Amps	
Compliance Voltage, Laser Diode Load	Full Temp. Range, I _{LD} = 2.0 Amps, 5V	3.0			Volts	
Rise Time	I _{LD} = 2 Amps		460		nsec	
Fall Time	I _{LD} = 2 Amps		320		nsec	
Bandwidth	Constant Current, Sine Wave		1.6		MHz	
Bandwidth	Constant Power	(Depends on PD BW)				
Delayed Start			0.25		Seconds	
Slow Start Ramp Rate			0.01		Seconds	
POWER SUPPLY						
Voltage, V _{DD}		5		12	Volts	
Current, V _{DD} supply, quiescent		5	10	15	mA	
INPUT						
Offset Voltage, initial, I _{mon}	Pin 2, T _{AMBIENT} = 25°C, V _{CM} = 0V		1	5	mV	
Bias Current (based on input Res of op amp)	Pin 2, T _{AMBIENT} = 25°C, V _{CM} = 0V		20	50	nA	
Common Mode Range	Pin 2, Full Temperature Range	0		V _{DD}	V	
Common Mode Rejection, Set point	Full Temperature Range	60	85		dB	
Power Supply Rejection	Full Temperature Range	60	80		dB	
VSET Damage Threshold		< -0.5	> V _{DD} + 0.5		V	

Note [1]. With Revision D of the WLD3343, an internal thermostat has been added to activate Shutdown (SHD) when the internal temperature exceeds 105°C. The output will be re-enabled after a 250 to 300 msec slow-start once the internal temperature drops below 95°C.

Temperature Controller PARAMETER	TEST CONDITIONS	MIN	TYP	MAX	UNITS
TEMPERATURE CONTROL					
Short Term Stability, 1 hour	TSET = 25°C using 10 kΩ thermistor	0.001	0.002	0.010	°C
Long Term Stability, 24 hour	TSET = 25°C using 10 kΩ thermistor	0.003	0.008	0.010	°C
Control Loop		P	PI		
P (Proportional Gain)		18	20	22	A/V
I (Integrator Time Constant)		2	3	4	Sec.
Setpoint vs. Actual T Accuracy	TSET = 25°C using 10 kΩ thermistor		<0.2%(Rev B)		
OUTPUT					
Current, peak, see SOA Chart		±1.8	±2.0	± 2.2	Amps
Compliance Voltage, Pin 11 to Pin 12	Full Temp. Range, I _{OUT} = 100 mA	V _S - 0.7	V _S - 0.5		Volts
Compliance Voltage, Pin 11 to Pin 12	Full Temp. Range, I _{OUT} = 1 Amp	V _S - 1.2	V _S - 1.0		Volts
Compliance Voltage, Pin 11 to Pin 12	Full Temp. Range, I _{OUT} = 1.5 Amps	V _S - 1.6	V _S - 1.4		Volts
Compliance Voltage, Pin 11 to Pin 12	Full Temp. Range, I _{OUT} = 2.0 Amps	V _S - 1.8	V _S - 1.6		Volts
Compliance Voltage, Resistive Heater	Full Temp. Range, I _{OUT} = 2.0 Amps	V _S - 1.7	V _S - 1.6		Volts
POWER SUPPLY					
Voltage, VDD		4.75		12	Volts
Current, VDD supply, quiescent			55	105	mA
Voltage, V _s		4.5		28	Volts
Current, V _s supply, quiescent		20	50	100	mA
INPUT					
Offset Voltage, initial	Pins 2 and 9		1	2	mV
Bias Current	Pins 2 and 9, T _{AMBIENT} = 25°C		20	50	nA
Offset Current	Pins 2 and 9, T _{AMBIENT} = 25°C		2	10	nA
Common Mode Range	Pins 2 and 9, Full Temp. Range	0		VDD-2 ^[2]	V
Common Mode Rejection	Full Temperature Range	60	85		dB
Power Supply Rejection	Full Temperature Range	60	80		dB
Input Impedence			500		kΩ
Input voltage range		GND		VDD-2 ^[2]	Volts
THERMAL					
Heatspreader Temperature Rise	T _{AMBIENT} = 25°C	28	30	33	°C/W
Heatspreader Temperature Rise	With WHS302 Heat sink and WTW002 Thermal Washer	18	21.5	25	°C/W
Heatspreader Temperature Rise	With WHS302 Heat sink, WTW002 Thermal Washer and 3.5 CFM fan	3.1	3.4	3.9	°C/W
Pin Solderability	Solder temp @260°C		10		Sec

^[2] The bias source has a compliance up to VDD-2.0 V. In normal operation this limits the sensor voltage range from 0.25V to VDD-2.0V. While voltages up to +/- 5V outside this range on the Vset pin will not damage the unit, it will not provide proper control under these conditions.

NOTE: Operation higher than 5V on VDD (i.e. 12V) requires close evaluation of the SOA curves and current limit settings. Damage to the WLD or WTC will occur if they are operated outside their Safe Operating Area. Contact the factory if you plan to use higher than 5V.

PIN DESCRIPTIONS

Connector 1 (J1)

Pin	Pin #	Name	Function
VDD	1 (RED)	Supply Voltage to Control Electronics and Laser Diode	Connect +5 to +12 V between pins 1 & 3 to power the control electronics and the output drive to the Laser Diode. Use the online Safe Operating Area calculator to make sure maximum internal power dissipation in the WLD is not exceeded - especially when using greater than +5 V.
VS	2 (WHT)	Supply Voltage to Output TEC Drive	Connect +5 to +28 V between pins 2 & 3 to drive the TEC output stage - Use the online Safe Operating Area calculator to make sure maximum internal power dissipation in the WTC is not exceeded - especially when using greater than +5 V.
GND	3 (BLK)	Power Supply Ground	Connect power supply ground to this pin.

Connector 2 (J2)

COM	1 (TAN)	Common	Low current GND for monitors, DACs, External VSET, etc. PIN 1 not available on Rev. A
PD MON	2 (PNK)	PD Monitor in CC mode	Photodiode Monitor in constant current mode PIN 2 not available on Rev. A
LD SHD	3 (GRY)	LD Shutdown / Interlock (TTL-Compatible)	Float or GND = Enable Laser Diode Current Input >3V = Disable Laser Diode Current
COM	4 (VLT)	Common	Low current GND for monitors, DACs, External VSET, etc.
R LDSET	5 (YEL)	Remote Laser Diode Setpoint/Modulation Input	Voltage Input range is 0 to 2 V. Transfer function: $V_{R\ LDSET} = I_{LD} * (2 R_{SENSE})$
COM	6 (ORG)	Common	Low current GND for monitors, DACs, External VSET, etc.
LD P M	7 (BLU)	Photodiode Monitor	Monitor the laser diode power. The Photodiode Current Monitor produces a voltage proportional to the current produced by the laser diode monitor photodiode.
LD I M	8 (BRN)	LD Current Monitor	Monitor the laser diode forward current. The Laser Diode Current Monitor produces a voltage proportional to the current flowing through the laser diode.
ACT T M	9 (GRN)	Actual Temp Monitor	Monitor the actual voltage produced by the temperature sensor. The voltage produced and transfer function to temperature is determined by the sensor chosen.
SET T M	10 (RED)	Setpoint Monitor	Monitor the temperature setpoint voltage. The voltage produced and transfer function to temperature is determined by the sensor chosen.
R TCSET	11 (WHT)	Remote Temperature Setpoint	Connect a voltage source between Pin 11 (VSET) and Pin 12 (GND) to control the temperature setting remotely. A default value of 1 V (about room temperature with 10 kΩ thermistor) will be seen by the WTC if the voltage at this pin drops below 0.3 V.
COM	12 (BLK)	Common	Low current GND for monitors, DACs, External VSET, etc.

Connector 3 (J3)

LDC	1 (BLK)	Laser Diode Cathode	Laser diode cathode connection
PDA	2 (WHT)	Photodiode Anode	Photodiode anode connection
PDC	3 (BLU)	Photodiode Cathode	Photodiode cathode connection
LDA	4 (RED)	Laser Diode Anode	Laser diode anode connection
COM	5 (GRN)	Common	Low current GND
TEC+	6 (RD/BK)	TEC + connection	Cooling current flows from this pin when using an NTC sensor.
TEC-	7 (ORG)	TEC - connection	Heating current flows from this pin when using an NTC sensor.
SEN+	8 (WT/BK)	Temperature Sensor +	Connect resistive and LM335 type temperature sensors across Pin 8 and Pin 9. Connect a 10 kΩ resistor across these pins when using AD590 type temperature sensors. The negative terminal of the AD590 sensor connects to Pin 8 and the positive terminal to Pin 1 (VDD) of Connector 1. AD590 operation requires that VDD be +8 Volts or greater for proper operation.
SEN-	9 (OR/BK)	Temperature Sensor -	
COM	10 (GR/BK)	Common	Low current GND for monitors, DACs, External VSET, etc.

TYPICAL PERFORMANCE GRAPHS - WLD

Caution:

Do not exceed the Maximum Internal Power Dissipation of the WLD or WTC.
Safe Operating Area (SOA) tools are provided online to make your design easier.
Exceeding the Maximum Internal Power Dissipation voids the warranty.

To determine if the operating parameters fall within the SOA of the device, the maximum voltage drop across the driver and the maximum current must be plotted on the SOA curves.

These values are used for the example SOA determination for a WLD:

$$V_S = 12 \text{ Volts}$$

$$V_{LOAD} = 5 \text{ Volts}$$

$$I_{LOAD} = 1 \text{ Amp}$$

} These values are determined from the specifications of the laser diode, and in the context of the specific application.

Follow these steps:

1. Determine the maximum voltage drop across the driver, $V_S - V_{LOAD}$, and mark on the X axis.
Example: 12 Volts - 5 Volts = 7 Volts (Point A)
2. Determine the maximum current, I_{LOAD} , through the driver and mark on the Y axis:
Example: 1 Amp (Point B)
3. Draw a horizontal line through Point B across the chart. (Line BB)
4. Draw a vertical line from Point A to the maximum current line indicated by Line BB.
5. Mark V_S on the X axis. (Point C)
6. Draw the Load Line from where the vertical line from point A intersects Line BB down to Point C.

Refer to the chart shown below and note that the Load Line is outside the Safe Operating Areas for use with no heatsink (1) or the heatsink alone (2), but is within the Safe Operating Area for use with heatsink and Fan (3).

An online tool for calculating your load line is at <http://www.teamwavelength.com/support/calculator/soa/soald.php>

WLD Series Safe Operating Area

Graphs assume:
25°C Case

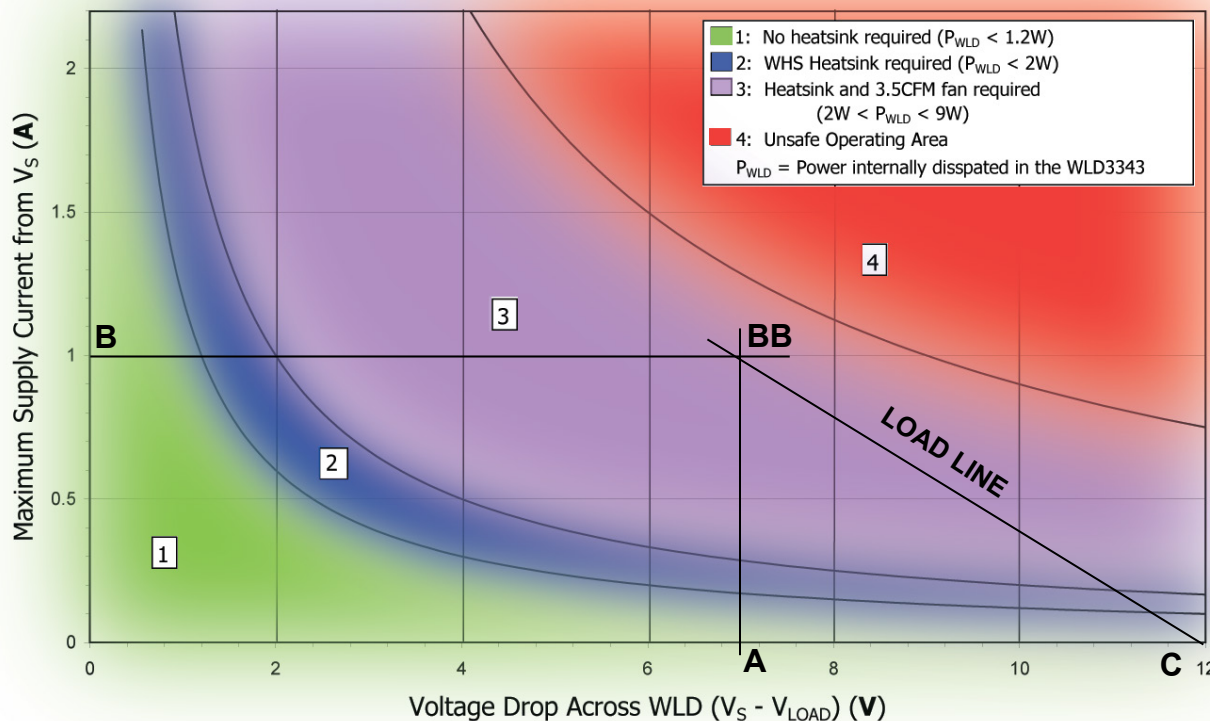

Caution:

Do not exceed the Maximum Internal Power Dissipation of the WLD or WTC. Safe Operating Area (SOA) tools are provided online to make your design easier. Exceeding the Maximum Internal Power Dissipation voids the warranty.

To determine if the operating parameters fall within the SOA of the device, the maximum voltage drop across the controller and the maximum current must be plotted on the SOA curves.

These values are used for the example SOA determination for a WTC:

$V_S = 12$ Volts
 $V_{LOAD} = 5$ Volts
 $I_{LOAD} = 1$ Amp

} These values are determined from the specifications of the thermal load, and in the context of the specific application.

Follow these steps:

1. Determine the maximum voltage drop across the controller, $V_S - V_{LOAD}$, and mark on the X axis.
Example: 12 Volts - 5 Volts = 7 Volts (Point A)
2. Determine the maximum current, I_{LOAD} , through the controller and mark on the Y axis:
Example: 1 amp (Point B)
3. Draw a horizontal line through Point B across the chart. (Line BB)
4. Draw a vertical line from Point A to the maximum current line indicated by Line BB.
5. Mark V_S on the X axis. (Point C)
6. Draw the Load Line from where the vertical line from point A intersects Line BB down to Point C.

Refer to the chart shown below and note that the Load Line is outside the Safe Operating Areas for use with no heatsink (1) or the heatsink alone (2), but is within the Safe Operating Area for use with heatsink and Fan (3).

An online tool for calculating your load line is at <http://www.teamwavelength.com/support/calculator/soa/soatc.php>.

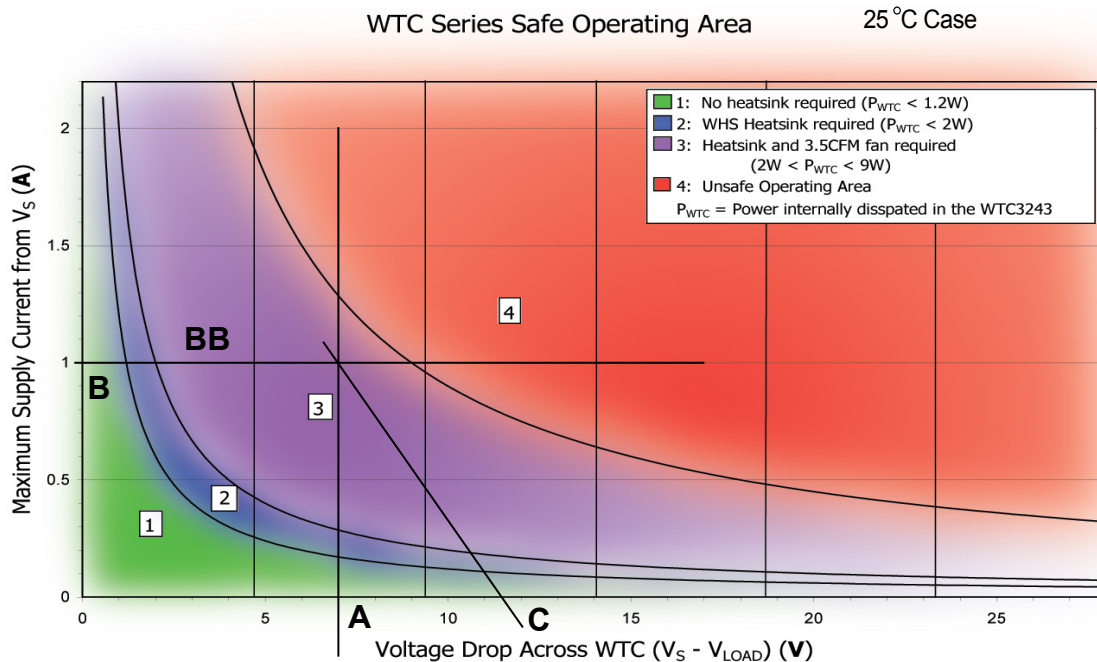

Proper heat dissipation from the WLD & WTC is critical to longevity of the LDTC 2/2. The heat spreaders of the WTC3243 and WLD3343 are positioned to use your chassis for heat dissipation. Be sure to add thermally conductive paste to all relevant surfaces that need to dissipate heat.

Recommended order of setup:

WTC configuration should be addressed first, using a simulation diode load in place until the temperature control section is working properly. After the temperature control section is operating according to preferences, then the laser diode load can be configured. Using a simulated diode load until you are comfortable with WLD configuration and operation is recommended in order to avoid any potential damage to an expensive laser diode.

CAUTION:

Operate the LDT2/2 with all loads attached - if you short either the LD or TC output connections during setup, current will flow and possibly overheat / damage the WLD or WTC.

1. CONFIGURING HEATING AND COOLING CURRENT LIMITS

The LDT2/2 has two trimpots that independently set the heating and cooling current limits: LIM A & LIM B. These are 12-turn 5 kΩ trimpots. Full current (2.2 A) is at full CCW position. Table 1 shows the meaning of the trimpots with various sensors and load types. Note that PTC sensors include RTDs, the LM335, and the AD590.

Table 1

Trimpot function vs. Sensor & Load Type

Sensor Type	Load Type	LIM A Limits:	LIM B Limits:
Thermistor	Thermoelectric	Cool Current	Heat Current
PTC	Thermoelectric	Heat Current	Cool Current
Thermistor	Resistive Heater	OFF = Fully CW	Heat Current
PTC	Resistive Heater	Heat Current	OFF = Fully CW

2. WIRE OUTPUT CONNECTION

Use Table 2 to determine the connection from the LDT2/2 to your thermoelectric or resistive heater.

Table 2

Wiring vs. Sensor & Load Type

Sensor Type	Load Type	TEC+ Connector 3, Pin 6	TEC - Connector 3, Pin 7
Thermistor	Thermoelectric	Thermoelectric positive wire	Thermoelectric negative wire
PTC	Thermoelectric	Thermoelectric negative wire	Thermoelectric positive wire
Thermistor	Resistive Heater	Quick Connect: Connect the Resistive Heater to TEC+ & TEC - (polarity doesn't matter). Adjust the Cooling Current Limit A trimpot to zero - fully CW. Max V Connect: Connect one side of the resistive heater to TEC- and the other side to the voltage source V_s . LIM A trimpot setting is then irrelevant.	
PTC	Resistive Heater	Quick Connect: Connect the Resistive Heater to TEC+ & TEC - (polarity doesn't matter). Adjust the Cooling Current Limit B trimpot to zero - fully CW. Max V Connect: Connect one side of the resistive heater to TEC- and the other side to the voltage source V_s . LIM B trimpot setting is then irrelevant.	

3. CONNECT TEMPERATURE SENSOR

The LDT2/2 is configured to operate a 10 kΩ thermistor with a 100 μA bias current. If your application requires a different sensor, please contact Wavelength for details. Wire the thermistor between pins 8 & 9 (SENS+ & SENS-) on Connector J3. Operating without a temperature sensor will drive maximum current through the WTC, potentially damaging it.

WTC OPERATION, continued

4. PROPORTIONAL GAIN AND INTEGRATOR TIME CONSTANT - PI TERMS

The LDTC2/2 is configured to the mid-range positions appropriate for most laser diode loads. To adjust these parameters to optimize the temperature control system time to temperature or stability, contact Wavelength.

5. POWER SUPPLY SELECTION

The V_{DD} voltage supply input is common to both the WLD3343 and the WTC3243. This supply furnishes the voltage to the control electronics of the devices as well as the compliance voltage for the WLD3343 Laser Driver.

The supply should be capable of providing at least 3.0 Amps of current in applications that use a separate V_S supply in the temperature control implementation. Temperature control applications that tie V_{DD} and V_S together require a V_{DD} current capacity that equals the sum of the maximum TEC or Resistive Heater current, plus the maximum laser diode current, plus approximately 200 mA for the control electronics of the WTC3243 Temperature Controller and the WLD3343 Laser Driver, plus current to an optional fan. Using the maximum potential of the WLD and WTC will not require more than 6.0 Amps.

V_S is the voltage that is applied to the TEC or Resistive Heater. This voltage should be high enough to supply the voltage required by the TEC or Resistive Heater plus the compliance required by the WTC. The voltage available to the TEC will be from between 0.5 to 1.8 V lower than V_S . To minimize power dissipation in the WTC, keep V_S as low as possible.

Calculate the maximum power dissipation of your design **before applying power to the LDTC2/2.**

6. TEMPERATURE SETPOINT

Wavelength introduces a special setpoint circuit with the LDTC2/2. An on-board trimpot (TSET) will adjust the voltage from 0.3 V to 2.5 V. Additionally, Pins 11 (R TC SET) & 12 (COM) of Connector J2 will accept a DAC voltage (from 0.3 to 2.5 V). The new feature - the "Failsafe Setpoint" will default the setpoint to 1 V (~25°C for a 10 k Ω thermistor) if the chosen signal (from pot or DAC) falls below 0.3 V.

A jumper set lets you choose to use only the on-board potentiometer or the external voltage.

Figure 2

Source of Setpoint

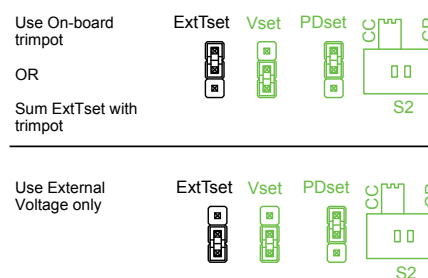

JP1 configures the Remote Temperature Setpoint choice. There is about 100 mV of hysteresis built into the default voltage. The input impedance of the R TC SET is greater than 20 k Ω and is fully buffered.

If you use a different sensor or would prefer a different default voltage, contact Wavelength.

7. MONITOR ACTUAL TEMP AND SETPOINT

Pins 9 & 10 of Connector J2 are ACT T Monitor and SET T Monitor respectively. Measure the actual sensor voltage across Pin 9 and Pin 12 (COM). For a 10 k Ω thermistor with 100 μ A bias current, the resistance (in k Ω) is given by:

$$R = \frac{V_{J2PIN 9}}{0.1}$$

To monitor the setpoint voltage used by the WTC, use Pins 10 and 12.

8. ENABLE CURRENT TO TEC

Output current is supplied to the load as soon as power is applied to the controller. The Power LED indicator will light GREEN when power is applied.

Online Safe Operating Area (SOA) calculators are available at:

<http://www.teamwavelength.com/support/calculator/soa/soatc.php>

Configuration of the LDTC for Alternate Sensors

LM335

To use a National Semiconductor, LM335 temperature sensor with the LDTC, attach the LM335 cathode to Sensor+ and the LM335 anode to Sensor-. R_{BIAS} , shown in Figure 3 should be changed to 2 k Ω for a bias current of 1 mA through the sensor.

The voltage output of the LM335 is 10 mV / K.

NOTE: The ExtTset must be used for setting the temperature when using the LM335.

AD590

To use an Analog Devices AD590 temperature sensor with the LDTC, first remove R_{BIAS} shown in Figure 3.

Connect the positive lead of the AD590 to a voltage supply ≥ 8 V and the negative lead to the Sensor+ pin on the LDTC. The AD590 produces a current of 1 μ A per degree Kelvin, giving a transfer function of 10 mV / K with a 10 k Ω resistor connected between Sensor+ and ground.

Figure 3

Location of Sensor Bias Resistor

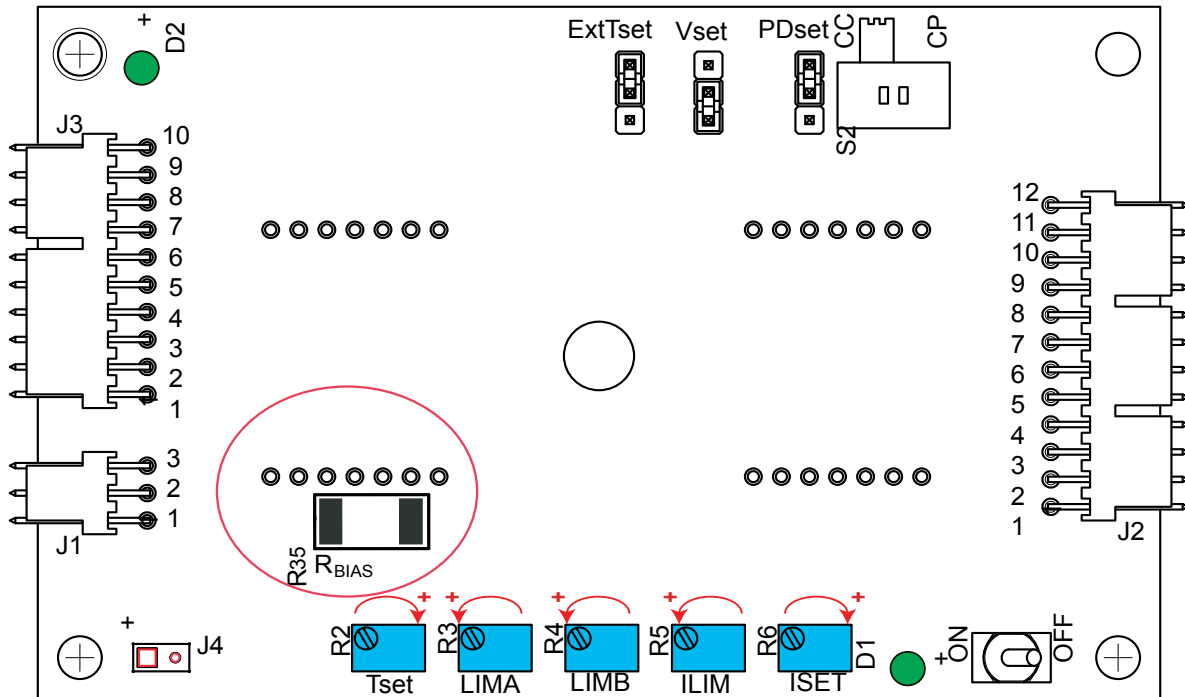

WLD OPERATION

Recommended order of setup:

WTC configuration should be addressed first, using a simulation diode load in place until the temperature control section is working properly. After the temperature control section is operating according to preferences, then the laser diode load can be configured. Using a simulated diode load until you are comfortable with WLD configuration and operation is recommended in order to avoid any potential damage to an expensive laser diode.

1. SELECTING THE LASER DIODE OUTPUT CURRENT RANGE

The output current range of the WLD3343 depends on the selection of resistor R_{SENSE} . Two 2520-sized resistors combine in series to produce this total R_{SENSE} resistance (R14 & R15).

$$R_{SENSE} = R_{14} + R_{15}$$

The LDTC2/2 defaults the maximum range to 2.2 Amps. To change the range, and the sensitivity of the setpoint voltage, use Table 3 or Equation 1, and install the appropriate R_{SENSE} resistance.

Table 3

Laser Diode Current Sense Resistor R_{SENSE} vs Maximum Laser Diode Current I_{LDMAX}

Maximum Output Current	Constant Power Current Sense Resistor, R_{SENSE}	Constant Current Current Sense Resistor, R_{SENSE}
I_{LDMAX}	R_{SENSE}	R_{SENSE}
50 mA	25.00 Ω	20.00 Ω
125 mA	10.00 Ω	8.00 Ω
250 mA	5.00 Ω	4.00 Ω
500 mA	2.50 Ω	2.00 Ω
1.25 Amps	1.00 Ω	0.80 Ω
2.2 Amps	0.57 Ω	0.45 Ω

2. HELPFUL HINTS FOR CHOOSING R_{SENSE}

- Never use a carbon film resistor for R_{SENSE} .
- Avoid resistors with high parasitic inductance.
- Select a resistor with a low temperature coefficient (1%, < 100 ppm / °C).
- Use Equation 2 for determining the power rating of R_{SENSE} .

NOTE: Wavelength Electronics recommends a conservative power rating of 1.25 times normal maximum for R_{SENSE} . Equation 2 incorporates this recommendation.

CAUTION:

Operate the LDTC2/2 with all loads attached - if you short either the LD or TC output connections during setup, current will flow and possibly overheat / damage the WLD or WTC.

Figure 4

Location of R_{SENSE}

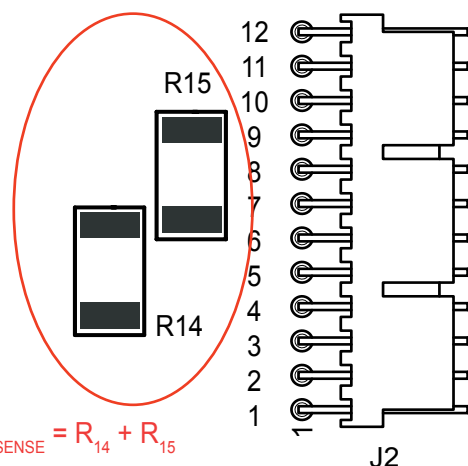

Equation 1

Calculating R_{SENSE}

Constant Power Mode

$$R_{SENSE} = \frac{1.25}{I_{LDMAX}}$$

Constant Current Mode

$$R_{SENSE} = \frac{1.00}{I_{LDMAX}}$$

Equation 2

Calculating The Power Rating for R_{SENSE}

$$RATING = 1.25 * (I_{LDMAX})^2 * R_{SENSE}$$

3. CHOOSE OPERATING MODE - CONSTANT CURRENT OR CONSTANT POWER

A sliding switch (S2) selects operating mode. Do not move this switch while power is applied or you risk damaging your laser diode.

In Constant Current mode, Laser Diode I_{SET} correlates directly to the laser diode current, regardless of laser diode power intensity. In Constant Power mode, the LDTC controls the laser diode using the photodiode to achieve a laser light intensity that is directly proportional to Laser Diode I_{SET} .

Select the mode of operation for the LDTC with the power off by setting the sliding switch S2 to the CC position for Constant Current mode or the CP position for Constant Power mode.

4. SELECT THE MONITOR PHOTODIODE CURRENT RANGE- for Constant Power Operation

Select between two ranges on the LDTC2/2 board: 200 μ A or 2.0 mA. A jumper (JP3) selects the range. Move this jumper only when power is not applied to V_{DD} .

Figure 5
Select Photodiode Range



CAUTION: Online Safe Operating Area (SOA) calculators are available for the WLD3343. Calculate the maximum power dissipation of your design at <http://www.teamwavelength.com/support/calculator/soa/soald.php> before applying power to the LDTC2/2.

The transfer function of the setpoint voltage depends on this setting for Constant Power Operation. If you choose the wrong setting, you could overdrive your laser diode.

If you would prefer a different range, contact Wavelength.

5. POWER SUPPLY SELECTION

The VDD voltage supply input is common to both the WLD3343 and the WTC3243. This supply furnishes the voltage to the control electronics of the devices as well as the compliance voltage for the WLD3343 Laser Driver.

The supply should be capable of providing at least 3.0 Amps of current in applications that use a separate V_s supply in the temperature control implementation. Temperature control applications that tie V_{DD} and V_s together require a V_{DD} current capacity that equals the sum of the maximum TEC or Resistive Heater current, plus the maximum laser diode current, plus approximately 200 mA for the control electronics of the WTC3243 Temperature Controller and the WLD3343 Laser Driver. Using the maximum potential of the WLD and WTC will not require more than 6.0 Amps.

Performance of the laser driver is very dependent upon the performance of the power supply. The LDTC 2/2 does provide some filtering of the power supply input. For optimal performance, a power supply that can provide the appropriate level of noise and ripple for the application at hand should be utilized.

Wavelength Electronics offers a selection of switching or linear power supplies in a range of output voltage and current capacities.

6. DISABLING THE OUTPUT CURRENT

The output current can be enabled and disabled as shown in Figure 6 using the on-board toggle switch.

A remote voltage signal can be used to control the output status of the laser driver. Float or connect a zero Volt signal to the "LD SHD" (Pin 3 on Connector J2) to ENABLE output current to the laser diode. A voltage level greater than 3 V, but less than 5 V, will DISABLE output current to the laser diode. This input was designed for TTL inputs.

The external LD SHD signal to Pin 3 has complete control when the onboard LD Enable switch is in the ENABLE position.

NOTE:

In order to avoid potential damage to the laser, do not insert or remove the laser diode from the WLD3343 circuit with power applied to the unit. Always turn off the power to the unit prior to making any circuit modifications and always use proper operator grounding and anti-static procedures.

7. MONITOR LASER DIODE OR PHOTODIODE CURRENT

Equation 3 provides a transfer function for converting the voltage output of LD I M (Laser Diode Current Monitor - Pin 8 of Connector J2) to the amount of forward current flowing through the laser diode. Default R_{SENSE} is 0.4 Ω , so

$$\text{default } I_{LD} = V_{LDIM} / 0.8$$

Equation 4 provides a transfer function for converting the voltage output of LD P M (Laser Diode Power Monitor - Pin 7 of Connector J2) to the amount of forward current flowing through the photodiode. R_{PD} varies with the Photodiode Current range:

$$R_{PD} = 499 \Omega \text{ for } 2.0 \text{ mA range or } 4.99 \text{ k}\Omega \text{ for } 200 \mu\text{A range}$$

Photodiode current can be monitored in Constant Current Mode by monitoring J2 Pin 2 (PD MON) with a voltmeter. (NOTE: PIN 1 & 2 on J2 are not available on Rev. A.) The photodiode current is then given by:

$$I_{PD} = \frac{V_{PDMON}}{2 \times 499} \quad (2 \text{ mA range})$$

$$I_{PD} = \frac{V_{PDMON}}{2 \times 4.99K} \quad (200 \mu\text{A range})$$

Figure 6
Disabling Output Current

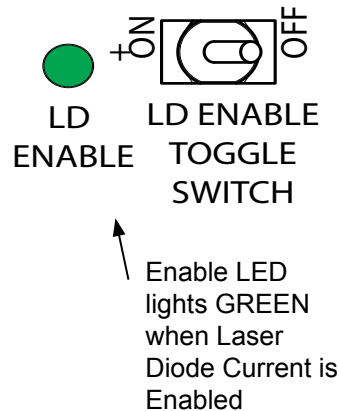

Equation 3
Laser Diode Forward Current Measurement

$$I_{LD} = \frac{V_{LDIM}}{2 * R_{SENSE}} \quad [\text{AMPS}]$$

Equation 4
Monitor Photodiode Current Measurement in Constant Current Mode:

NOTE: Available Rev. B and later.

$$I_{PD} = \frac{V_{LDP M}}{2 * R_{PD}}$$

WLD OPERATION, continued

**8. CONFIGURE THE LASER
DIODE CURRENT LIMIT**

The default configuration of the LDTC2/2 uses a trimpot to adjust the Current Limit from 0 to the maximum range set in Step 1- WLD Operation. This trimpot is labeled ILIM (vs. LIM A or LIM B for the temperature control limit current trimpots). Fully CCW sets the limit current to the maximum. It is recommended that a simulated laser diode load is used while limit current is set. Follow Step 7 to monitor Laser Diode Current. Adjust the trimpot until the appropriate voltage is measured.

**9. LASER DIODE SETPOINT AND
MODULATION**

The laser diode setpoint voltage determines the amount of current that is delivered to the laser. In Constant Current mode the setpoint is directly proportional to the laser diode current. In Constant Power mode the setpoint is directly proportional to the photodiode current, allowing for control of the optical power of the light emitted by the laser diode.

The setpoint voltage can be adjusted either by using the onboard ISET trimpot, by applying an external setpoint voltage, or by summing an external setpoint voltage with the setpoint voltage created by adjustment of the ISET trimpot. The sum of the external setpoint voltage and the voltage created with the onboard ISET trimpot can be from zero to 2.5 volts.

To use only the onboard ISET trimpot, place the VSET SOURCE jumper in the lower position (as shown below), and do not connect an external voltage source to the R LD SET input. The ISET trim pot provides a setpoint adjustment of between zero to 2.5 V.

Figure 7
Laser Diode Setpoint Configuration

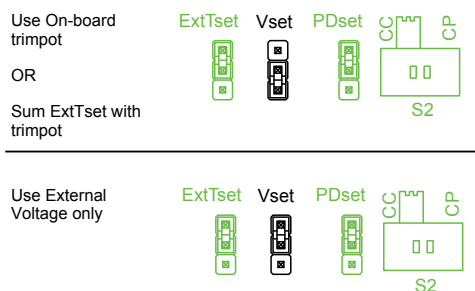

To use an external voltage source summed with the voltage supplied by the SET trimpot, place the VSET SOURCE jumper in the lower position (as shown in Figure 7). Connect the external voltage, or DAC output, to the R LD SET input (pin 5 on Connector J2). The final setpoint voltage will be the sum of the external voltage being supplied plus any Set Point voltage created with the onboard SET trimpot.

To use only an external voltage source for the setpoint voltage place the VSET SOURCE jumper in the upper position (pins 1 and 2 on JP2) and connect the external setpoint voltage via the R LD SET input. In this configuration, any voltage created by the onboard ISET trimpot will not be included in the final setpoint voltage which is applied to the laser driver.

Equation 5 illustrates the relationship between setpoint voltage ($V_{R LD SET}$) and the current that will be applied to the laser diode according to the current range that has been configured for the driver using standard R_{SENSE} resistances.

Equation 5:

$$I_{LD} = \frac{V_{R LD SET}}{2 * R_{SENSE}} \text{ [AMPS]}$$

R_{SENSE} default is 0.4Ω.

Equation 6 illustrates the relationship between setpoint voltage ($V_{R LD SET}$) and the resulting photodiode current while operating in Constant Power mode for the two standard photodiode ranges that can be configured on the LDTC 2/2.

Equation 6:

$$I_{PD} = \frac{V_{R LD SET}}{2 * R_{PD}} \text{ [AMPS]}$$

$R_{PD} = 499 \Omega$ for 2.0 mA range or
4.99 kΩ for 200 μA range

$I_{PD} = V_{R LD SET} / 1000$ for 2.0 mA range default
or

$I_{PD} = V_{R LD SET} / 10000$ for 200 μA range default

Modulation caution - if operating with V_{DD} at 12 V and you exceed 12 V on R LD SET with the modulation signal for any duration, the WLD will be destroyed.

WARNING:

The LDTC 2/2 does not support laser diode packages that incorporate a built in sensor that is connected to or common with the laser case ground.

STEPS FOR REPLACING THE WTC/ WLD:

Disassemble the LDTC:

1. Remove cables from the unit.
2. Lift straight up on the cover to remove it from the base.
3. Remove PCB from the base plate by carefully pulling it off the corner posts.
4. Remove the eight screws on the bottom of the baseplate that attach the WLD and WTC to the base plate.
5. Use a small screwdriver to separate the WLD and WTC from the base plate.

Reassemble the LDTC:

1. Plug the new part(s) into the PCB board before attaching it to the base to ensure that the pins do not get bent.
2. Make sure that the thermal sil pad or thermal paste is in good shape in order to tightly couple the WLD/WTC heat spreader to the mounting plate or heat sinking surface. Replace a questionable sil pad or spread a new thin coat of thermal paste.
3. Seat the holes on the PCB onto the corner posts and press PCB into seated position.
4. Install the eight screws in the WLD and WTC.
5. Install the cover and cables.

ORDERING INFORMATION:

LDTC2/2E	Comes with PCB board, WLD, WTC, mounting plate, enclosure, cables
LDTC2/2O	Comes with PCB board, WLD, WTC, standoffs & hardware, cables

For easy heasing of Open Frame Model:

WEV-300	Standard WLD or WTC thermal washer and heatsink
WEV-301	Standard WLD or WTC thermal washer, heatsink, and 5 V fan
WEV-302	Standard WLD or WTC thermal washer, heatsink, and 12 V fan

MECHANICAL SPECIFICATIONS -
LDT C2/2 E - with enclosure

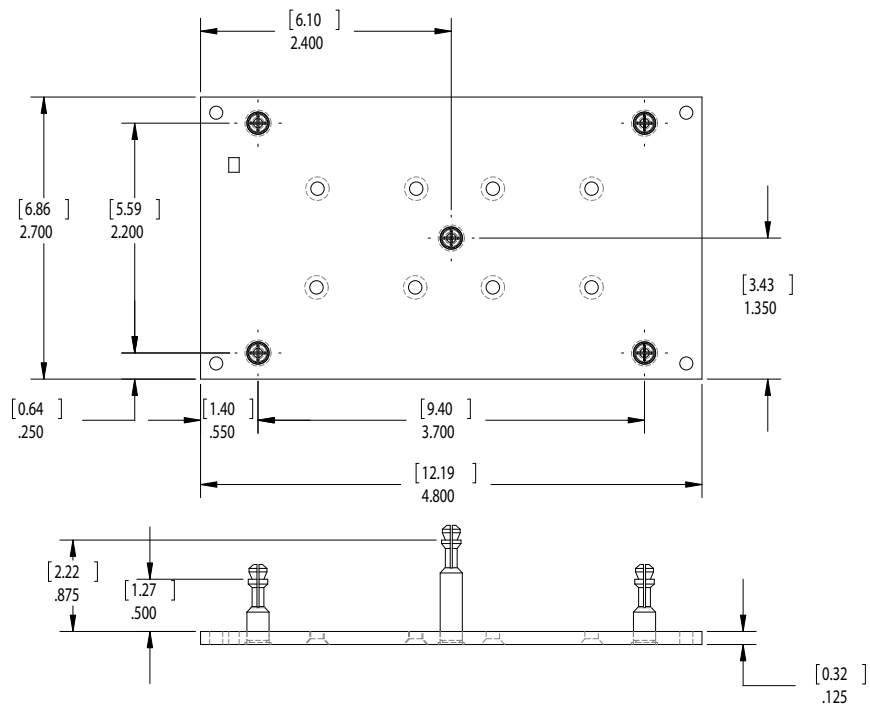
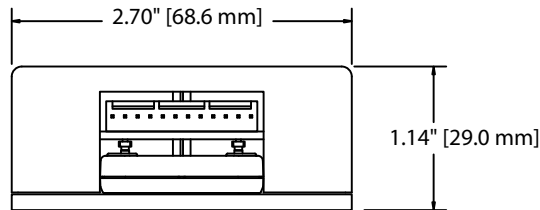
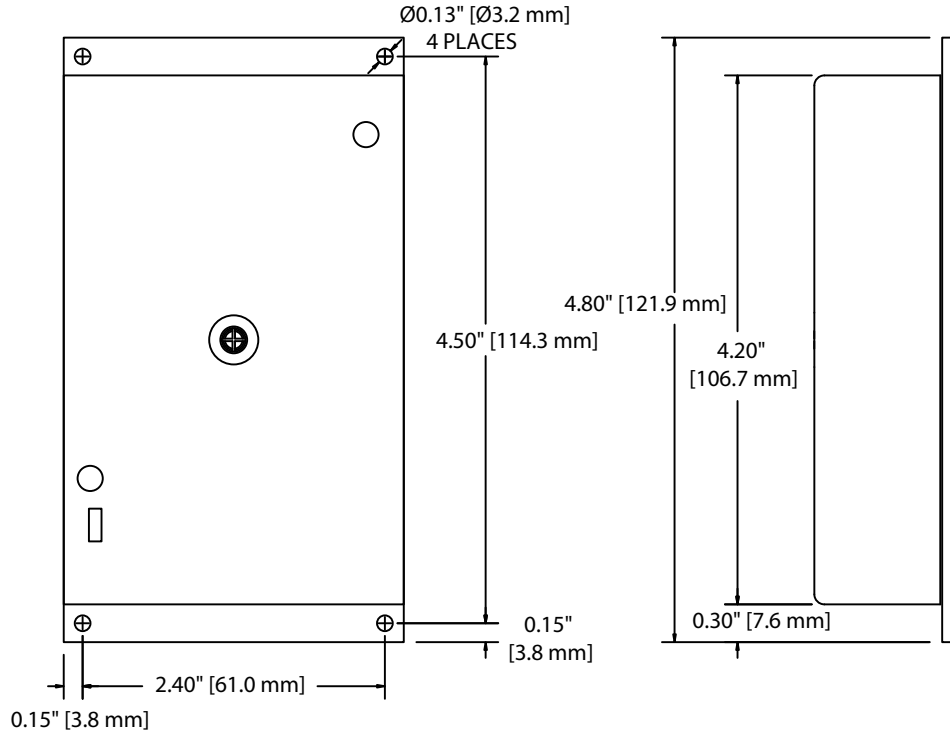

MECHANICAL SPECIFICATIONS - LDTC2/2 O - Open Frame

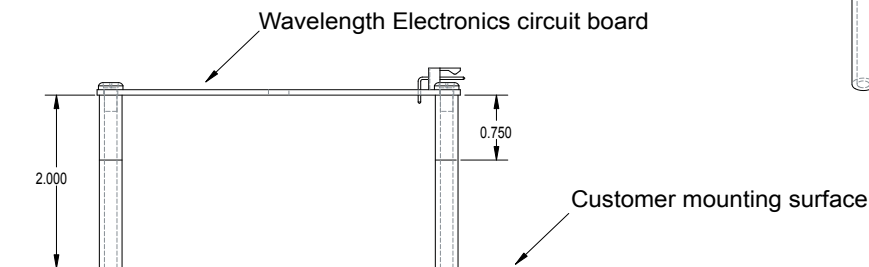
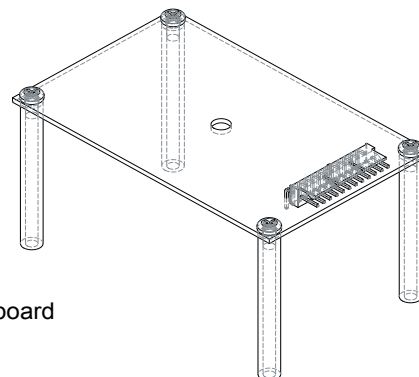
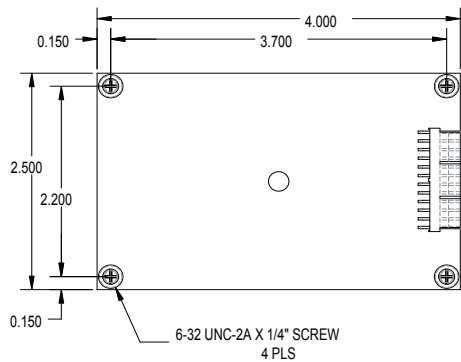
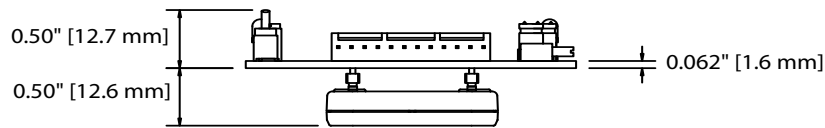
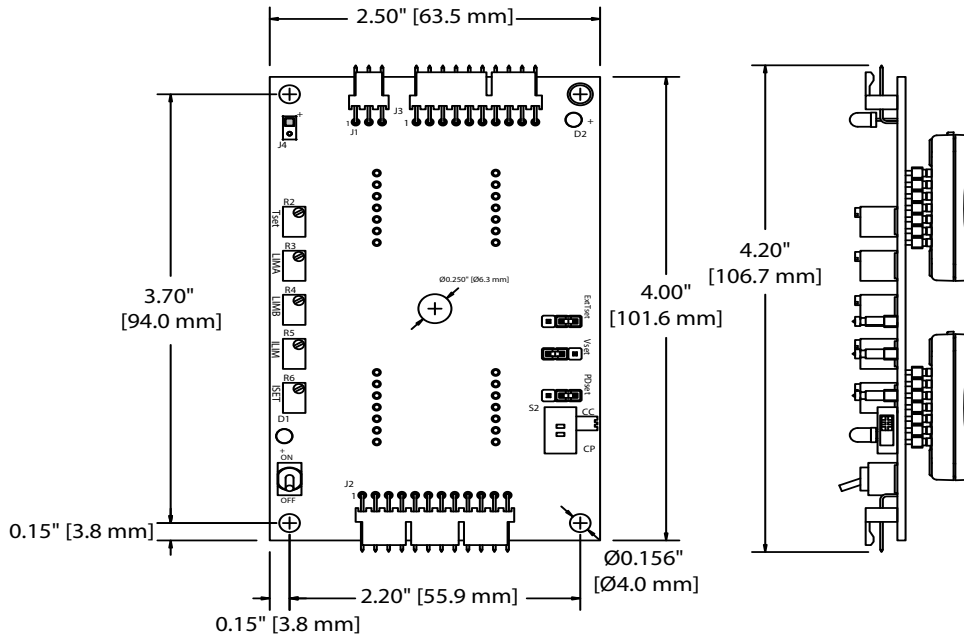

Use the longer standoff when mounting unit with a fan.
Use the smaller standoff for mounting directly to instrument.

**POWER
(WCB300)
Connects to J1**

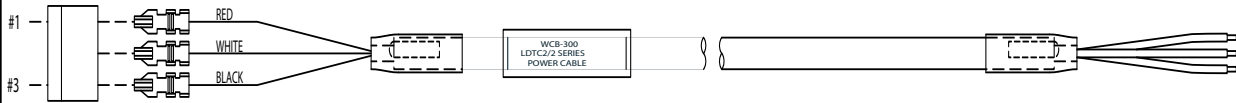

PIN	WIRE COLOR
1 (VDD)	RED
2 (VS)	WHITE
3 (GND)	BLACK

**OUTPUT to TEC & LD
(WCB301)
Connects to J3**

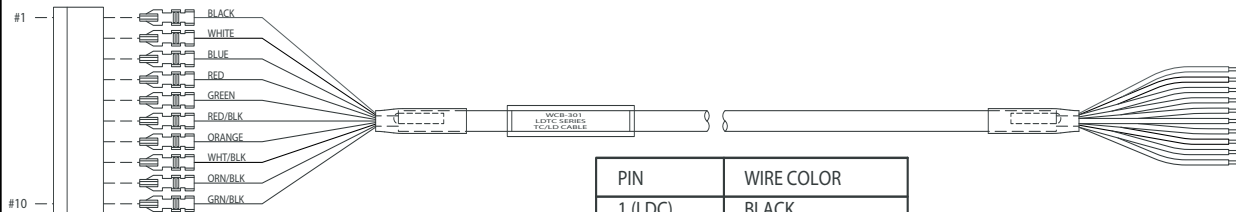

PIN	WIRE COLOR
1 (LDC)	BLACK
2 (PDA)	WHITE
3 (PDC)	BLUE
4 (LDA)	RED
5 (COM)	GREEN
6 (TEC+)	RED/BLACK
7 (TEC-)	ORANGE
8 (SEN+)	WHITE/BLACK
9 (SEN-)	ORANGE/BLACK
10 (COM)	GREEN/BLACK

**I/O
(WCB309)
Connects to J2**

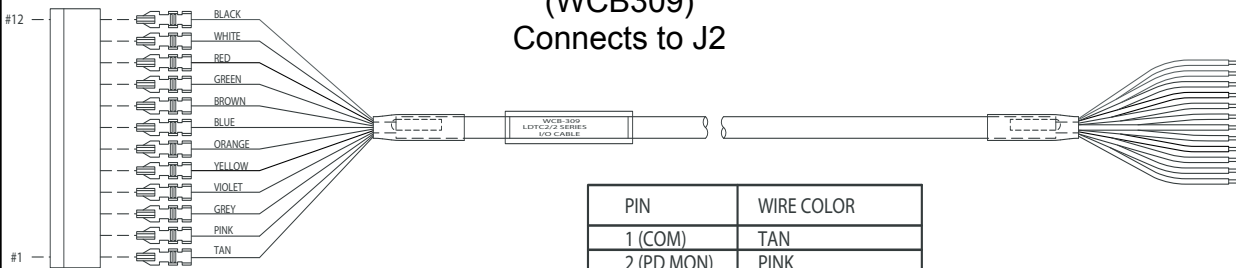

PIN	WIRE COLOR
1 (COM)	TAN
2 (PD MON)	PINK
3 (LD SHD)	GREY
4 (COM)	VIOLET
5 (R LDSET)	YELLOW
6 (COM)	ORANGE
7 (LD PM)	BLUE
8 (LD IM)	BROWN
9 (ACT T M)	GREEN
10 (SET T M)	RED
11 (R TCSET)	WHITE
12 (COM)	BLACK

NOTE: LDTC2/2 E & O Rev A DO NOT HAVE PINS 1 & 2 of WCB309. These were labeled as spares for Rev. A

CERTIFICATION AND WARRANTY**CERTIFICATION:**

Wavelength Electronics, Inc. (Wavelength) certifies that this product met its published specifications at the time of shipment. Wavelength further certifies that its calibration measurements are traceable to the United States National Institute of Standards and Technology, to the extent allowed by that organization's calibration facilities, and to the calibration facilities of other International Standards Organization members.

WARRANTY:

This Wavelength product is warranted against defects in materials and workmanship for a period of 90 days from date of shipment. During the warranty period, Wavelength will, at its option, either repair or replace products which prove to be defective.

WARRANTY SERVICE:

For warranty service or repair, this product must be returned to the factory. An RMA is required for products returned to Wavelength for warranty service. The Buyer shall prepay shipping charges to Wavelength and Wavelength shall pay shipping charges to return the product to the Buyer upon determination of defective materials or workmanship. However, the Buyer shall pay all shipping charges, duties, and taxes for products returned to Wavelength from another country.

LIMITATIONS OF WARRANTY:

The warranty shall not apply to defects resulting from improper use or misuse of the product or operation outside published specifications.

No other warranty is expressed or implied. Wavelength specifically disclaims the implied warranties of merchantability and fitness for a particular purpose.

EXCLUSIVE REMEDIES:

The remedies provided herein are the Buyer's sole and exclusive remedies. Wavelength shall not be liable for any direct, indirect, special, incidental, or consequential damages, whether based on contract, tort, or any other legal theory.

REVERSE ENGINEERING PROHIBITED:

Buyer, End-User, or Third-Party Reseller are expressly prohibited from reverse engineering, decompiling, or disassembling this product.

NOTICE:

The information contained in this document is subject to change without notice. Wavelength will not be liable for errors contained herein or for incidental or consequential damages in connection with the furnishing, performance, or use of this material. No part of this document may be translated to another language without the prior written consent of Wavelength.



WAVELENGTH ELECTRONICS, INC.
51 Evergreen Drive
Bozeman, Montana, 59715

SAFETY:

There are no user serviceable parts inside this product. Return the product to Wavelength for service and repair to ensure that safety features are maintained.

LIFE SUPPORT POLICY:

As a general policy, Wavelength Electronics, Inc. does not recommend the use of any of its products in life support applications where the failure or malfunction of the Wavelength product can be reasonably expected to cause failure of the life support device or to significantly affect its safety or effectiveness. Wavelength will not knowingly sell its products for use in such applications unless it receives written assurances satisfactory to Wavelength that the risks of injury or damage have been minimized, the customer assumes all such risks, and there is no product liability for Wavelength. Examples of devices considered to be life support devices are neonatal oxygen analyzers, nerve stimulators (for any use), auto transfusion devices, blood pumps, defibrillators, arrhythmia detectors and alarms, pacemakers, hemodialysis systems, peritoneal dialysis systems, ventilators of all types, and infusion pumps as well as other devices designated as "critical" by the FDA. The above are representative examples only and are not intended to be conclusive or exclusive of any other life support device.

REVISION HISTORY

REVISION	DATE	NOTES
REV. A	29-Aug-05	Initial release Contact factory if laser has LDA or LDC grounded.
REV. B	20-May-08	Updated to reflect product revision changes to improve ground bounce and setpoint drift
REV. C	4-Nov-08	Updated to clarify cabling and clearly indicate the differences between product Rev. A and Rev. B.
REV. D	31-Aug-09	Updated links to support new website
REV. E	11-Mar-10	Updated pin descriptions on page 6
REV. F	9-June-11	Clarified diagram details
REV. G	8-Dec-11	Corrected rise time & stability specifications
REV. H	22-Jun-12	Updated the I_{PD} formulas on page 15

phone: (406) 587-4910 Sales/Tech Support
fax: (406) 587-4911
e-mail: sales@teamwavelength.com
web: www.teamwavelength.com

