

# Syringe thermodynamics: The many uses of a glass syringe

David P. Jackson<sup>a)</sup> and Priscilla W. Laws

*Department of Physics and Astronomy, Dickinson College, Carlisle, Pennsylvania 17013*

(Received 28 July 2004; accepted 2 December 2005)

Glass syringes have precision fit low-friction pistons and are relatively inexpensive, which makes them an ideal tool for studying the thermal behavior of gases. The glass syringe is used to construct a thermometer, a miniature hydraulic press, and a working heat engine. Concepts illuminated by these experiments include temperature, pressure, the ideal gas law, work, internal energy, and the first law of thermodynamics. © 2006 American Association of Physics Teachers.  
[DOI: 10.1119/1.2162547]

## I. INTRODUCTION

During the past several decades introductory physics instruction has undergone a dramatic change as people have taken advantage of the power of computers and the results of physics education research. Today, it is not uncommon for students to work in workshop-style environments that deemphasize lectures in favor of hands-on experience.<sup>1</sup> With the aid of computer-based data acquisition tools,<sup>2</sup> students can collect, display, and analyze data quickly and easily, allowing them to perform a wide range of experiments. As an example, the act of throwing an object can now be analyzed by tracking the object's motion using a motion sensor. This analysis gives students instant feedback on how the position, velocity, and acceleration vary as the object moves along its trajectory. Similar demonstrations exist for almost all aspects of introductory mechanics.

Compared to mechanics, designing experimental activities for thermodynamics is much more challenging. Concepts such as temperature, pressure, heat, and internal energy are very abstract. In fact, the operation of a heat engine is mystifying to most students. Several instructors have designed pedagogically sound activities using disposable plastic syringes,<sup>3,4</sup> but their use is limited by the fact that there is a considerable amount of friction between the plunger and the cylinder. In contrast, glass syringes<sup>5</sup> are precision-made so the piston moves with relatively little friction in the barrel. This lack of friction makes them ideal for use in a number of experiments that are almost impossible to perform with plastic syringes. Although glass syringes are more expensive than plastic syringes,<sup>6</sup> their wide range of uses makes them an excellent investment even in cost-conscious departments.

In this article, we describe a series of activities that can be performed using a glass syringe and a data acquisition system. All of these activities can be used in a standard introductory physics course and many are appropriate for non-science students as well. Although a few of these experiments may be familiar to some readers, we will focus our attention on experiments that have not been extensively discussed in the literature. We hope that these experiments will offer some new insights into the learning of thermodynamics.

## II. THE SYRINGE THERMOMETER

One of the first concepts typically introduced in the study of thermodynamics is temperature. It often is pointed out that the expansion properties of materials (such as a liquid) can be used as the basis for measuring temperature. To increase student motivation and understanding, we have students con-

struct a constant-pressure gas thermometer, which using a glass syringe and a flask takes just a few minutes. The thermometer is constructed by connecting a 10-cc syringe to a 25-ml Erlenmeyer flask with a piece of plastic tubing.<sup>7</sup> The syringe is then held in an upright position with a clamp, while the flask serves as the temperature sensitive bulb to be placed in hot or cold water (see Fig. 1); the piston rises or falls in response.<sup>8</sup>

Students often are surprised by the behavior of these thermometers and naturally ask questions such as: Is the gas temperature really the same as the water temperature? What about the temperature of the gas in the syringe? Will this thermometer still work if the atmospheric pressure changes? These questions are the kinds we want our students to ask because they lead to a number of interesting issues that are not usually discussed in depth in an introductory course. These include what is actually measured by a thermometer, the physical limits of thermometers, and whether or not a thermometer affects the measurement process.

This activity can be made more quantitative by having the students invent their own temperature scale (in cc). This activity demonstrates the fact that all temperature scales (and all measurement scales) are arbitrary. What makes them useful is the fact that everyone agrees to use the same system. Students can calibrate their thermometers by using a hot and cold source of known temperature and create a conversion equation between their temperature scale and the Celsius scale.

## III. PRESSURE AND THE SYRINGE MACHINE

Before introducing the concept of pressure, we first give students a chance to experience the fact that gases can exert forces. Simply playing with a glass syringe and asking questions is a good way to motivate students and get them thinking about the forces that gases can exert. For example, by having students place a finger over the end of the syringe when the piston is about halfway out and then holding it in various orientations, they will see that the piston seems to “defy gravity” (see Fig. 2).<sup>9</sup> If they push or pull on the piston (with their finger still over the end) they will immediately experience a rather large restoring force. By asking some straightforward questions about these situations, students can be led to understand that the gas inside the syringe exerts a force on the piston that depends on the volume of the gas (this dependence is a precursor to Boyle's law). We can then use this information to assert that the position of the piston

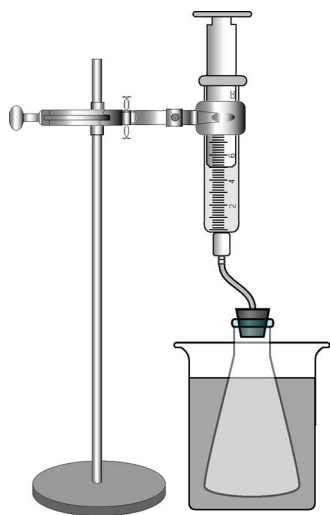

Fig. 1. A schematic of a syringe thermometer consisting of a glass syringe connected to a flask bulb. The flask is placed in a cup of water and the piston moves up or down in response.

must change when turning the syringe from right side up to upside down as shown in Fig. 2; careful observations will support this assertion.

Unless students have been motivated through experience to understand the need for the concept of pressure, defining pressure simply as the “force per unit area” is not very illuminating. An excellent way to help students develop this motivation is through a hydraulic press, whereby a very small force can be used to lift something that would normally require a much larger force. Using glass syringes, it is easy to put together such a device. The idea is to connect two glass syringes of different diameters using a short length of plastic tubing as shown in Fig. 3. We call this device the “syringe machine,” which is a hydraulic press with air as the working medium. With this setup, we can place a mass on one of the pistons and lift it by pushing down on the other piston.

The most dramatic aspect of the syringe machine is the relatively large difference in force needed to lift a mass when it is placed on one piston compared to the other. This force difference can be quite dramatic because there is a hydraulic

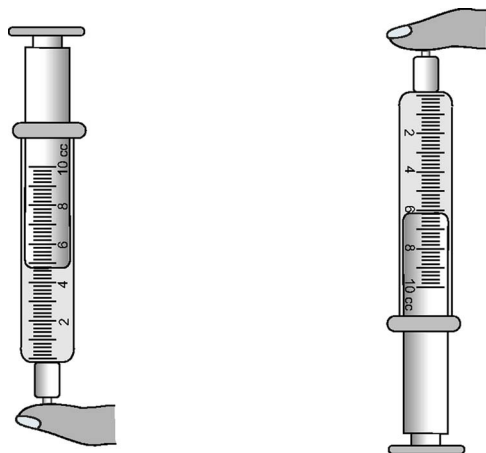

Fig. 2. A glass syringe held with a finger over the end leads to a situation where the piston seems to defy gravity.

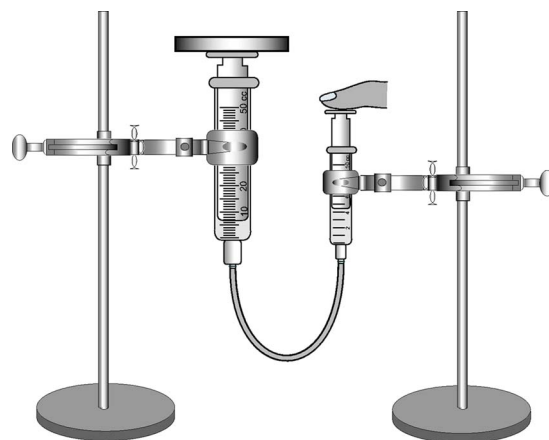

Fig. 3. A miniature hydraulic press is produced when two glass syringes with different cross-sectional areas are connected together with a plastic tube. The resulting syringe machine is an excellent way to motivate the need for the concept of pressure.

advantage that makes the mass feel “lighter” when it is sitting on the large piston where  $F_1 = (A_1/A_2)mg$ , and there is a hydraulic disadvantage that makes the mass feel “heavier” when sitting on the small piston where  $F_2 = (A_2/A_1)mg$ .<sup>10</sup> The net effect is that the ratio of forces needed to lift the mass is given by

$$\frac{F_2}{F_1} = \left(\frac{A_2}{A_1}\right)^2 = \left(\frac{d_2}{d_1}\right)^4, \quad (1)$$

where  $A_i$  and  $d_i$  are the cross-sectional area and diameter of piston  $i$ , respectively, and  $F_i$  is the force exerted on piston  $i$  that is needed to lift the mass. For example, connecting a 50-ml syringe ( $d_2 = 2.8$  cm) to a 5-ml syringe ( $d_1 = 1.2$  cm) will result in a force ratio of about 30. That means that it will take approximately 30 times more force to lift a mass placed on the small piston than to lift the same mass when it is placed on the large piston. When students (and faculty) experience such an extraordinary difference in force, it makes a memorable impression.

When performing this experiment in class, it is more effective to have students begin by placing the mass on the large piston first so it takes very little effort to lift the mass. Then, after quickly moving the mass to the small piston, it seems enormously difficult to lift the mass. This kinesthetic experience provides much motivation for understanding what is going on.

Typically, a lively discussion will follow such an experiment and students will invariably bring up the fact that the two syringes have different cross-sectional areas. There is general consensus among students that pushing on the skinnier piston should be easier than pushing on the larger piston because there is less gas in its way. Additionally, students note that the piston in the smaller syringe moves through a larger distance than the piston in the larger syringe. This observation provides a good opportunity to review the concept of work and demonstrates that while the syringe machine can produce a force advantage, the work done while pushing down is exactly equal to the work done in lifting the mass.

To make this experiment quantitative, students use a force sensor (instead of their finger) to lift the mass. Although this sounds simple, it is a bit tricky to perform this experiment

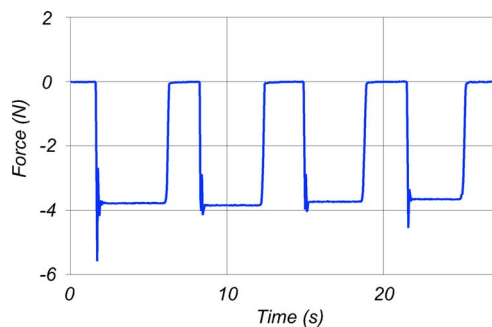

Fig. 4. Plot of the force needed to lift a mass using the syringe machine shown in Fig. 3. The force is negative because of the force sensor setup.

and obtain reliable data. We obtain the best results by mounting the force sensor and allowing the piston to push up against it. Then we push down and release the piston a few times to make several independent measurements. This procedure can be done in a single experiment that takes only about 30 s to perform. Figure 4 shows some sample data for this force measurement. In this particular experiment, a 200-g mass was sitting on a 20-ml syringe piston ( $d=2.00$  cm,  $m=29.2$  g) while a force sensor recorded the force necessary to lift the mass by pushing down on a 50-ml syringe piston ( $d=2.80$  cm,  $m=66.2$  g).

When students compare the force on one side of the syringe machine (weight of mass plus weight of piston) to the force on the other side (applied force plus weight of piston), they are not surprised that they are unequal. This situation in which two *unequal* forces acting on the same “object” are balanced is rather strange. Clearly, the gas does not behave like a regular object in the sense that a regular object, when acted on by unequal forces, will accelerate in the direction of the larger force. Thus, it is somewhat unclear how to treat the gas in this situation.

A reasonable way to proceed is to consider that the downward force acting on each piston must be balanced by an equal magnitude upward force that comes from the gas itself. Accordingly, the gas exerts a (proportionally) larger force when it is in contact with a larger surface area. Thus, it is plausible that the quantity  $F/A$  may be an important property of the gas. Table I shows the results for the data shown in Fig. 4. The data confirm the hypothesis and allow us to give a meaningful definition for the pressure of a gas as  $P=F/A$ .

#### IV. THE IDEAL GAS LAW

The ideal gas law can be written as  $PV=NkT$ , where  $P$ ,  $V$ , and  $T$  are the pressure, volume, and temperature of the gas, respectively,  $N$  is the number of gas particles, and  $k$  is Boltzmann’s constant. It often is assumed that students can easily manipulate this equation appropriately. However, recent studies have shown that students make all kinds of incorrect

Table I. Force, area, and pressure data for the experiment shown in Fig. 4. Agreement is typically within a few percent.

	Piston 1	Piston 2
Avg force (N)	4.40	2.25
Area (cm <sup>2</sup> )	6.16	3.14
$F/A$ (N/cm <sup>2</sup> )	0.714	0.716

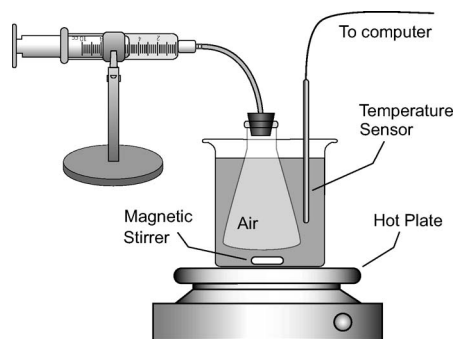

Fig. 5. Experimental setup for studying the temperature-volume relation of an ideal gas. An air-filled flask is submerged in a beaker of water that is heated with a hot plate. A flexible tube joins the flask to a glass syringe.

assumptions when dealing with this equation.<sup>11</sup> We try to give students a better feel for the ideal gas law by having them do a number of simple quantitative experiments. By holding the amount of gas fixed ( $N$  constant), students can examine the three possible relations between pressure, volume, and temperature, by performing the following experiments:

- (1) Hold pressure constant and examine  $V$  vs  $T$ .
- (2) Hold volume constant and examine  $P$  vs  $T$ .
- (3) Hold temperature constant and examine  $P$  vs  $V$ .

Of these three experiments, only the first requires the use of a glass syringe. The second requires no syringe at all, and the third requires a plastic syringe that can withstand much larger pressure differences than a glass syringe. All three experiments are straightforward, and careful measurements can lead to excellent results. We discuss all three experiments for completeness.

#### A. $V$ vs $T$

In this experiment we connect a glass syringe to a flask with flexible plastic tubing. The flask is held in a beaker of water sitting on a hot plate with magnetic stirring (see Fig. 5). If the room pressure does not change, the gas in the syringe/flask system will be at a constant pressure throughout the entire experiment. We use the hot plate to vary the temperature of the gas while temperature and volume measurements are taken.

Because the temperature sensor reacts relatively slowly to changing gas temperatures, it is problematic to try to measure the temperature of the gas directly. Instead, we measure the temperature of the water and assume that the gas is in thermal equilibrium with the water. This procedure is a good approximation as long as the temperature does not change too quickly.<sup>12</sup> (It generally takes about 30 min for the water temperature to increase from about 20 to about 80 °C.) As the temperature increases, we make visual readings of the syringe volume as it changes.<sup>13</sup> Gently spinning the piston in the barrel of the syringe helps to prevent any sticking during the experiment.

Students often point out that the gas in the syringe is not in contact with the water. Indeed, assuming the entire volume of gas is at the temperature of the water does not lead to particularly good results. Better results are obtained by assuming that the gas in the syringe is in thermal equilibrium

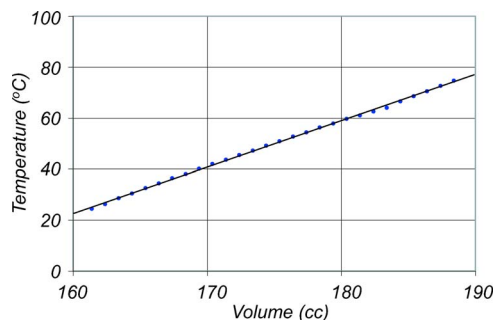

Fig. 6.  $T$ - $V$  data obtained using a 30-ml glass syringe. A least-squares linear fit also is shown. Extrapolating to zero volume gives an absolute zero of  $-267^\circ\text{C}$ .

with the room air while the gas in the flask is in thermal equilibrium with the water. The temperature of the gas is then calculated as a weighted average.

Figure 6 shows data taken using a 30-ml syringe and a 125-ml Erlenmeyer flask.<sup>14</sup> The linear relation between temperature and volume is clear. It is interesting to ask students what they think will happen if they continue to cool the gas further. That is, what will happen as the volume of the gas decreases to zero? Although most students have probably heard of absolute zero, this experiment provides a nice framework from which to understand how one might be led to postulate such a concept. Extrapolating the data in Fig. 6 to zero volume leads to an “absolute zero” of  $-267^\circ\text{C}$ .

### B. $P$ vs $T$

To measure pressure versus temperature, the flask is connected directly to the pressure sensor. As before, we assume the gas temperature to be the same as the water temperature and take data at a rate of about once per minute. The results are shown in Fig. 7. Again we see a rather impressive linear relationship that extrapolates to an “absolute zero” of  $-273^\circ\text{C}$ . The fact that the temperatures in this and the previous experiment both extrapolate to approximately the same value makes an impact on students.

### C. $P$ vs $V$

Measuring pressure versus volume is perhaps the most common of the three experiments. Here, a well-sealed plastic syringe is connected directly to the pressure sensor. Figure 8 shows the results using a 20-cc plastic syringe. As with the previous two experiments, the results are impressive. In this

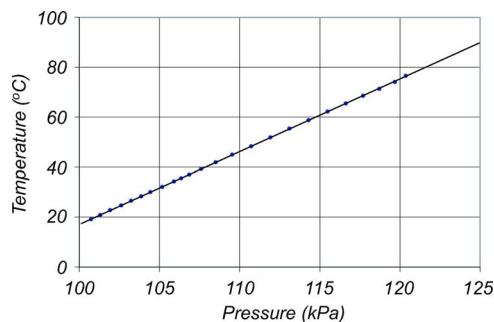

Fig. 7. The  $T$ - $P$  data also show a linear relation. A least-squares linear fit is shown. Extrapolation to zero pressure yields an absolute zero of  $-273^\circ\text{C}$ .

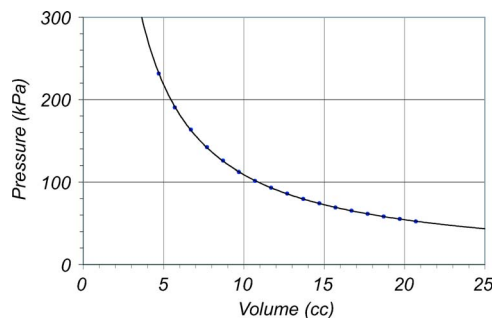

Fig. 8.  $P$ - $V$  data obtained using a 20-cc plastic syringe. The curve is a least-squares fit of the form  $P=c/V$ , where  $c$  is a constant.

experiment, it is important to account for the internal volume of the pressure sensor.<sup>13</sup> In addition, we obtain the best results by making the atmospheric pressure correspond to a volume of 10 cc and then changing the syringe volume in the same direction (either large to small or small to large) throughout the entire experiment.

After completing the three ideal gas law experiments, students can combine the results to confirm that they are consistent with the ideal gas law equation.

## V. WORK, INTERNAL ENERGY, AND THE FIRST LAW OF THERMODYNAMICS

The first law of thermodynamics can be mysterious to students. Even if we emphasize that the first law is a general statement of energy conservation, it is difficult for students to comprehend the first law without having a sound grasp of the concepts of work done on (by) a system, thermal energy transfer to (from) a system, and the internal energy of a system. A series of observations and thought experiments using the syringe connected to a flask help students become familiar with these concepts. Because it is difficult to confirm the first law in a quantitative manner, the following activities attempt to make the first law plausible by considering some special cases and relying on the principle of energy conservation.

### A. Work on a gas

The concept of work in physics is subtle and often misinterpreted.<sup>15</sup> Nevertheless, students can easily grasp the concept of doing work on a gas by providing them with the tools necessary to carry out this task. By using the glass syringe and flask arrangement shown in Fig. 1 (without the water), students can apply a force to the piston and thus do work on the piston; the piston in turn does work on the gas. Now is a good time to review the definition of work and ask students whether the work done on the gas is positive or negative depending on whether they are pushing or pulling on the piston. We can then do a guided derivation to show that the work done on the gas in the syringe is given by

$$W_{\text{on}} = \int_i^f \mathbf{F}_{\text{app}} \cdot d\mathbf{s} = - \int_i^f P dV. \quad (2)$$

It is critical for students to understand that Eq. (2) refers to the work done on the gas and that the force  $\mathbf{F}_{\text{app}}$  is the force that they apply to the piston. At this point, students should be asked to reconcile their previous answers regarding the



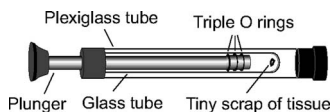

Fig. 9. A schematic diagram of a fire-syringe.

sign of the work done on the gas when they pull or push on the piston with Eq. (2). In this way they will learn to relate their intuitive sense of work done on the gas to Eq. (2).

In addition to the idea that work can be done on the gas, students also need to understand that the gas can do work on its surroundings. This understanding is easily accomplished by placing the flask into hot water (see Fig. 1) and feeling the force exerted by the piston on their finger or in lifting a small mass. We again can rely on students' strong intuition that the gas is doing work on the piston in this case. That is, work is being done by the gas. Of course, we can still apply Eq. (2) and see that the work done on the gas is negative. Again, the result of this experiment will resonate with students' intuition about the situation. At this point, we can derive the work done by the gas in a manner similar to the derivation of Eq. (2) to show that  $W_{\text{by}} = \int P dV = -W_{\text{on}}$ .

## B. Relating work to internal energy

The system shown in Fig. 1 also can be used to help students appreciate the need for the concept of internal energy. Because it is easy to do work on the gas by pushing on the piston, we can ask what happens to the energy it takes to do this work. In mechanics, the net work done on a point particle causes a change in the particle's kinetic energy. This relation is the work-kinetic energy theorem,

$$W = \Delta K = K_f - K_i. \quad (3)$$

Is there a similar principle for a gas? Does the work done on the system change its kinetic energy? Qualitatively the answer is yes. The work done on a gas can increase the kinetic energy of the many particles making up the gas. However, because there are many gas particles, it is much more complicated than dealing with a single point particle as in Eq. (3). However, we can still write down an equation that is reminiscent of the work-kinetic energy theorem. For example, assume the syringe/flask system is perfectly insulated so that there is no thermal energy  $Q$  transferred into or out of the system. In this situation, we have

$$W_{\text{on}} = \Delta U \quad (Q = 0), \quad (4)$$

where  $U$  is the *internal energy* of the system. Although kinetic energy (translational, rotational, and vibrational) is part of the internal energy of a gas, so is the potential energy that exists between the gas particles (which might include chemical, electrostatic, and nuclear). It should be stressed that the internal energy of the system is due to energies internal to the system (hence the name). Thus, the kinetic or potential energy of the system as a whole is not part of its internal energy.

A particularly memorable way to demonstrate that the internal energy of a gas increases when work is done on it is with a fire syringe.<sup>16</sup> This device is a cross between a glass syringe and a plastic syringe. A glass tube with a metal plunger is encased in a safety tube of plastic (see Fig. 9). The metal plunger is fitted with triple O-rings so that air is sealed

inside the glass tube. Pressing down very quickly on the plunger results in an approximately adiabatic compression ( $Q=0$ ) that increases the gas temperature dramatically (to almost 1000 K).<sup>17</sup> Thus, a tiny piece of tissue paper placed at the bottom of the glass tube can be made to self-ignite upon compression.<sup>18</sup> This activity easily convinces students that work done on a gas can increase its (internal) energy.

## C. Relating thermal energy to internal energy

We now return to a non-insulated syringe/flask system. We already have seen that when the flask is placed in hot water, the gas will do work by lifting the piston (and possibly a mass). This result clearly depends on a transfer of thermal energy to the system. The question we now pose is what happens if the piston is clamped in place so that the volume is held constant when the flask is placed in the hot water. In this case we have guaranteed that the system will do no work ( $W=0$ ), but there is still thermal energy being transferred to the system ( $Q_{\text{to}} > 0$ ). In this case, the internal energy of the system must increase by an amount equal to  $Q_{\text{to}}$ . Thus, we have

$$Q_{\text{to}} = \Delta U \quad (W = 0). \quad (5)$$

## D. Relating work and thermal energy to internal energy

We now turn to the general case when the thermal energy transfer and the work done are both nonzero. This case corresponds to placing the flask in hot water and allowing the piston to move. In this case, the thermal energy transferred to the system can be shared in two ways. Some of it increases the internal energy of the gas (as evidenced by its increasing temperature) and some of it is used to enable the gas to do work by lifting the piston through some distance. This relationship is summarized by

$$Q_{\text{to}} = W_{\text{by}} + \Delta U, \quad (6)$$

or in the more familiar form of the first law of thermodynamics,

$$\Delta U = Q_{\text{to}} - W_{\text{by}}. \quad (7)$$

Because we have already addressed the fact that  $W_{\text{by}} = -W_{\text{on}}$ , an alternate version of the first law is  $\Delta U = Q_{\text{to}} + W_{\text{on}}$ . This version can be viewed as a combination of Eqs. (4) and (5).

Equation (7) can be tested experimentally by incorporating a pressure sensor into the flask/syringe system shown in Fig. 1 (as in Fig. 10). The thermal energy transferred to the system can be found from  $Q_{\text{to}} = mc\Delta T$ , where  $m$  is the mass of the gas in the flask (*not* the mass in the entire system) and  $c$  is the constant pressure specific heat. The work done by the gas<sup>19</sup> is given by  $P\Delta V$  and the internal energy of air is given by  $U = \frac{5}{2}NkT$ . If we substitute these results into the first law equation, we have

$$\frac{5}{2}Nk\Delta T = mc\Delta T - P\Delta V, \quad (8)$$

which, using measured pressure, temperatures, and volumes, typically gives agreement to within about 5%. For example, an experiment using a 10-cc syringe (with a 100-g mass on the piston) and a 25-ml Erlenmeyer flask yielded  $\Delta U \approx 2.16$  J and  $Q_{\text{to}} - W_{\text{by}} \approx 2.07$  J.

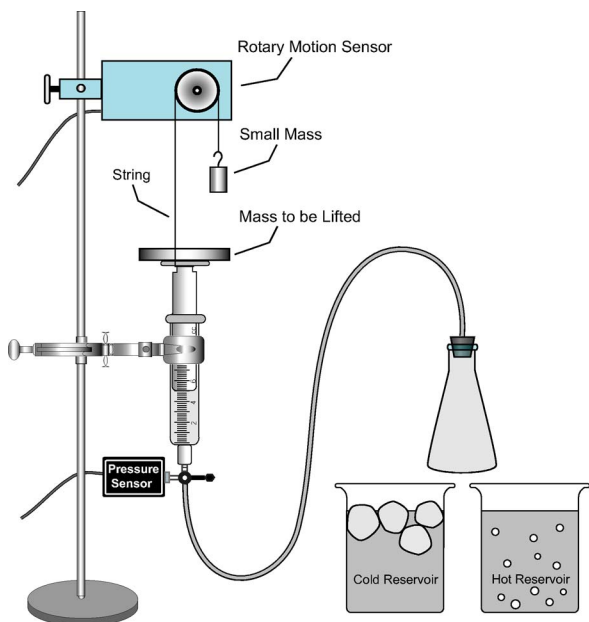

Fig. 10. An illustration of the mass lifting heat engine. A string attached to the piston is placed over a rotary motion sensor to measure volume changes of the system. The small mass is used to keep the string taut.

## VI. THE HEAT ENGINE

A typical nineteenth century heat engine was a complicated device full of chambers, pistons, levers, and gears. These trappings obscure the essential physical features of a heat engine. Early in the development of the Workshop Physics curriculum, we constructed a “mass lifting heat engine” designed originally by Dempsey and Hartman.<sup>20</sup> Although students were able to use this engine to relate the area bounded by the  $P$ - $V$  cycle to useful work, the nature of this engine was not obvious. With the help of PASCO Scientific, we designed a simple but elegant engine whose function is to lift masses from one level to another.<sup>21</sup> A 10-cc syringe attached to a 25-ml Erlenmeyer flask allows students to assemble a miniature low-cost heat engine that works quite well (see Fig. 10).

The syringe heat engine consists of a glass syringe connected to a flask that is transferred from cold water to hot water and back again. The pressure of the system is monitored with a pressure sensor, and the volume of the system can be measured using a rotary motion sensor or a motion detector. The basic mass-lifter engine cycle is shown in Fig. 11. The flask begins in cold water with no mass on the piston (point A in Fig. 11). Then a small mass is slowly (quasi-statically) placed on top of the syringe piston by hand (the conveyor belt shown in Fig. 10 is only an illustration). This isothermal process takes the engine to point B. The flask is then transferred to the hot water where the expanding air causes the piston (with mass) to rise in an isobaric process (point C). When the piston stops rising, the mass is slowly removed in another isothermal process, taking the system to point D. Finally, the flask is returned to the cold water and the piston descends in an isobaric process to its original height, thus completing the cycle.

One of the most important aspects of this heat engine is that it allows students an opportunity to experiment with a working heat engine. This involvement makes the abstract

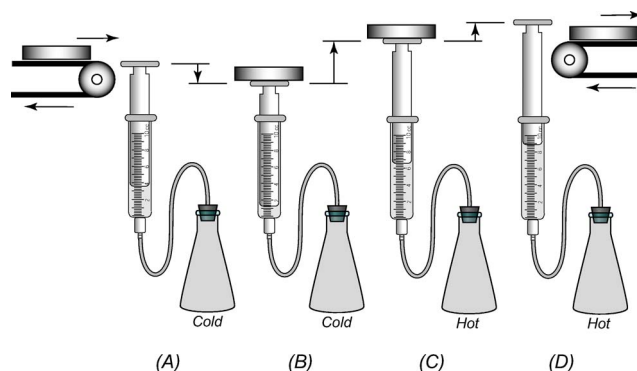

Fig. 11. The basic cycle of the mass lifting heat engine shown in Fig. 10. The conveyor belts are merely for illustration. The flask begins in cold water (A). A mass is then transferred to the piston (B). The flask is transferred to the hot reservoir and the piston lifts the mass (C). The mass is taken off the piston (D). The flask is then transferred back to the cold reservoir (A), and the cycle is repeated.

concept of a heat engine more concrete because students physically take the engine through its cycle. This engine is well suited for quantitative activities as well. For example, it is not difficult to make a real time  $P$ - $V$  diagram for this experiment. We can then compare the enclosed area to the actual work done in lifting the mass (see Fig. 12). The flask was transferred between a hot reservoir at 90 °C and a cold reservoir at 25 °C while the piston lifted a 100-g mass through a height of 2.7 cm. In this experiment, we found  $W_{\text{th}}=29$  mJ and  $W_a=26$  mJ, which gives a mechanical efficiency of 90%. Students can be asked to comment on why this result is not 100% and to estimate the frictional force in the syringe.<sup>22</sup>

To determine the thermodynamic efficiency, we calculate the thermal energy input for one cycle. This energy is estimated as the amount of energy required to raise the temperature of the air in the flask from 25 to 90 °C. We then find  $Q_h=mc\Delta T\approx 2.6$  J and a thermodynamic efficiency of  $\epsilon\approx 1.0\%$ . Compared to the Carnot efficiency of 18%, the efficiency of the mass lifting heat engine is very poor.

## VII. DISCUSSION

We have discussed the use of glass syringes in a variety of experiments, including the construction of a constant pres-

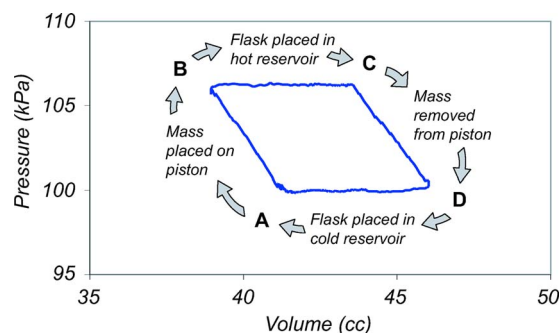

Fig. 12. A typical  $P$ - $V$  diagram for the mass lifting engine cycle described in Figs. 10 and 11. In this experiment, a 10-cc syringe was used with a 25-ml Erlenmeyer flask transferred between hot and cold reservoirs at 90 and 25 °C respectively. A 100-g mass was lifted through a height of 2.7 cm in this cycle.

sure gas thermometer, a mini-hydraulic press, and a working heat engine. These experiments can provide students with a rich qualitative experience, and when coupled with a computer-based data acquisition system, also can provide a solid quantitative experience. All of these experiments are appropriate for the standard introductory physics course and many can be used successfully in courses for non-science majors as well.

In addition to the activities we have discussed, a number of student projects have been described in the literature which make use of plastic and glass syringes. Various techniques and modifications of Rüchardt's method for measuring the ratio of specific heats (the adiabatic coefficient  $\gamma$ ) for gases have been described,<sup>23–26</sup> including the use of a glass syringe,<sup>27</sup> and computer-based data acquisition equipment.<sup>28</sup> Ferguson<sup>3</sup> has described an interesting modification of an experiment originally due to Lavoisier in which the oxygen content of air can be measured through a combustion process. His problem with plunger friction should be minimized with the use of a glass syringe. An interesting use of glass syringes to measure atmospheric pressure has been proposed.<sup>29</sup> This method relies on the fact that glass syringes cannot withstand large pressure differences without leaking. A similar experiment using a plastic syringe was discussed in Refs. 4 and 30.

The main feature of glass syringes that is exploited in these experiments is the very low friction between the piston and the barrel of the syringe. Unfortunately, because of this low friction, it is easy for the piston to slide right out of the barrel and smash on the floor if one is not careful. This occurrence is especially likely when students are handling the syringes. You cannot warn students enough of this potential danger.

Glass syringes will become a bit sticky with normal use, which can render them useless for many of the experiments we have described. Fortunately, it is easy to fix this problem by quickly moving the piston in-and-out of the syringe barrel a few times and/or twisting it a number of times. This procedure is continued until the piston slides easily in the barrel of the syringe when lifted and released. This technique works nearly 100% of the time. For those situations when this procedure is not satisfactory, the syringes can be cleaned using acetone or a detergent and de-ionized water. Despite the rather minor problem of maintaining their low friction characteristics, glass syringes can be the centerpiece for a number of experiments. Because they are relatively inexpensive, they are a welcome addition to the equipment of any physics department.

It is worth reemphasizing that glass syringes are not designed to withstand large pressure differences and for safety reasons should never be used in such situations. Even a modest amount of weight on a piston can lead to some leaking between the piston and the barrel.

## ACKNOWLEDGMENTS

The authors are indebted to David Sokoloff, Paul Stokstad, and Rob Lancaster, who made useful contributions to many of the experiments presented in this paper. We also gratefully acknowledge helpful discussions with Kerry Browne, Lars English, Hans Pfister, Jake Hopkins, and Harvey S. Leff. Much of the work presented in this paper was supported, in part, by NSF Grant No. DUE-9555188 and by FIPSE Grant Nos. P116B50999 and P116B000927.

<sup>a)</sup>Electronic mail: jacksond@dickinson.edu

<sup>1</sup>*Workshop Physics* was one of the first introductory physics curricula developed along these lines. See P. W. Laws, *Workshop Physics Activity Guide* (Wiley, New York, 2004).

<sup>2</sup>Many companies produce computer-based data acquisition systems. Two of the most popular are Vernier Software and Technology and PASCO Scientific.

<sup>3</sup>J. L. Ferguson, "The many uses of disposable plastic hypodermic syringes—A shot in the arm for small equipment budgets," *Am. J. Phys.* **46**, 1104–1106 (1978).

<sup>4</sup>G. T. Clayton, T. O. Callaway, and H. D. Downing, "Experiments with disposable hypodermic syringes," *Phys. Teach.* **26**, 19–21 (1988).

<sup>5</sup>Glass syringes can be purchased from a number of companies. We bought Perfectum syringes with luer-lock tips from Aldrich Chemical.

<sup>6</sup>Glass syringes typically cost approximately a dollar per cc. Thus, a 10-cc syringe will cost around \$10 and a 50-cc syringe will cost about \$50.

<sup>7</sup>You can also use a 50-cc syringe and 125-ml flask. It is relatively straightforward to calculate the relative sizes of the syringe and flask you need using the ideal gas law. For measuring water temperatures between freezing and boiling, the volume of the syringe should be about 35% of the total flask volume.

<sup>8</sup>It is important to use a flask that is dry on the inside. If there is liquid in the flask, it can evaporate as the temperature rises, resulting in a much larger gas volume than anticipated. This can result in the piston coming out of the syringe and breaking. It also can lead to moisture in the syringe, which compromises its low-friction nature.

<sup>9</sup>Note that this experiment is analogous to lifting liquid out of a cup by placing your finger over the end of a straw.

<sup>10</sup>Note that we are neglecting the mass of the pistons here for simplicity. When trying to make an accurate quantitative comparison, it is important to include the piston masses.

<sup>11</sup>M. E. Loverude, C. H. Kautz, and P. R. L. Heron, "Student understanding of the first law of thermodynamics: Relating work to the adiabatic compression of an ideal gas," *Am. J. Phys.* **70**, 137–148 (2002).

<sup>12</sup>A worst-case estimate for the time it takes the gas to equilibrate with the container can be made based on diffusion arguments. The mean-square displacement of a molecule in a particular direction is given by  $\bar{z}^2 = 2Dt$ , where  $D$  is the diffusion constant and  $t$  is time. If we take  $z_{\text{rms}}$  as the maximum distance from the container wall to the center (about 3 cm) and use the experimentally determined diffusion constant for nitrogen gas at room temperature ( $0.185 \text{ cm}^2/\text{s}$ ), we obtain  $t \approx 25 \text{ s}$ . The actual time should be much less than this due to convection.

<sup>13</sup>It is important to measure the entire volume of the syringe/flask system, including the volume in the connecting tubes. To measure the volume of the tubes, connect a plastic syringe (set to zero volume) to a pressure sensor via the tubes whose volume you want to measure and measure the pressure. Then pull out the piston until the pressure is reduced to half its original value. The reading on the syringe will then be exactly the volume of the tubes plus the internal volume of the pressure sensor.

<sup>14</sup>The data shown here were taken by a student with instructor assistance outside of class. Student data obtained in a classroom setting are not usually this good.

<sup>15</sup>For an excellent article discussing these subtleties, see A. J. Mallinckrodt and H. S. Leff, "All about work," *Am. J. Phys.* **60**, 356–365 (1992).

<sup>16</sup>Frey Scientific catalog number 15590034.

<sup>17</sup>The temperature can be estimated using the adiabatic equation for an ideal gas,  $T_f = T_i(V_i/V_f)^{\gamma-1}$ , where  $\gamma$  is the ratio of specific heats. For air,  $\gamma = 1.4$  at room temperature.

<sup>18</sup>Match heads have a lower ignition temperature than tissue paper and will be even easier to ignite. See C. H. Hayne and S. C. Baird, "Adiabatic compression in a fire syringe," *Phys. Teach.* **23**, 101–103 (1985).

<sup>19</sup>It is very tempting (but incorrect) to say that the work done by the gas is given by  $mgh$ , where  $m$  is the mass of the piston and  $h$  is the height that it is raised. This quantity is the net work done on the piston and is much smaller than the work done by the gas inside the syringe.

<sup>20</sup>Daniel Dempsey and J. Keith Hartman, " $pV$  cycle area equals work done: An undergraduate experiment," *Am. J. Phys.* **54**, 1086–1088 (1986).

<sup>21</sup>PASCO Scientific catalog number TD-8572.

<sup>22</sup>For this experiment, the entire distance traveled by the piston was 8.4 cm, which gives an average frictional force of 0.04 N.



- <sup>23</sup>C. G. Deacon and J. P. Whitehead, "Determination of the ratio of principle specific heats for air," *Am. J. Phys.* **60**, 859–860 (1992).
- <sup>24</sup>J. Mottmann, "Laboratory experiment for the ratio of specific heats of air," *Am. J. Phys.* **63**, 259–260 (1995).
- <sup>25</sup>S. Velasco, F. L. Román, and J. Faro, "A simple experiment for measuring the adiabatic coefficient of air," *Am. J. Phys.* **68**, 265–270 (1998).
- <sup>26</sup>O. L. de Lange and J. Pierrus, "Measuring the bulk moduli and ratio of specific heats of gases using Rüchardt's method," *Am. J. Phys.* **60**, 859–860 (2000).
- <sup>27</sup>J. L. Hunt, "Accurate experiment for measuring the ratio of specific heats of gases using an accelerometer," *Am. J. Phys.* **53**, 696–697 (1985). There appears to be a typo in Eq. (2) of this paper. To determine the

- undamped frequency  $f_0$  from the damped frequency  $f$ , one should use  $(f_0/f)^2 = 1 + [\lambda/(2\pi)]^2$ .
- <sup>28</sup>G. D. Severn and T. Steffensen, "A simple extension of Rüchardt's method for measuring the ratio of specific heats of air using microcomputer-based laboratory sensors," *Am. J. Phys.* **69**, 387–388 (2001).
- <sup>29</sup>S. Velasco, A. González, F. L. Román, and J. A. White, "A simple method for measuring atmospheric pressure," *Am. J. Phys.* **70**, 1236–1237 (2002).
- <sup>30</sup>A. R. Inversin, "Measuring atmospheric pressure with a syringe," *Phys. Teach.* **15**, 232–233 (1977).

**AAPT Announces  
New Online Journal:  
*Physical Review Topics—  
Physics Education Research***

A peer-reviewed, electronic journal exploring experimental and theoretical research on the teaching and learning of physics.

Edited by:  
Robert Beichner  
North Carolina State University

**Access Is Free!**

**Features:**

- review articles
- methodology critiques
- new assessment tools and research techniques

To learn more about the PER journal visit:  
<http://www.aapt.org/Publications/perjournal.cfm>

*Physical Review Special Topics—Physics Education Research*  
is sponsored by APS, AAPT, and the APS Forum on Education.