

Electron Diffraction Tube D 1013885

Instruction sheet

12/12 ALF

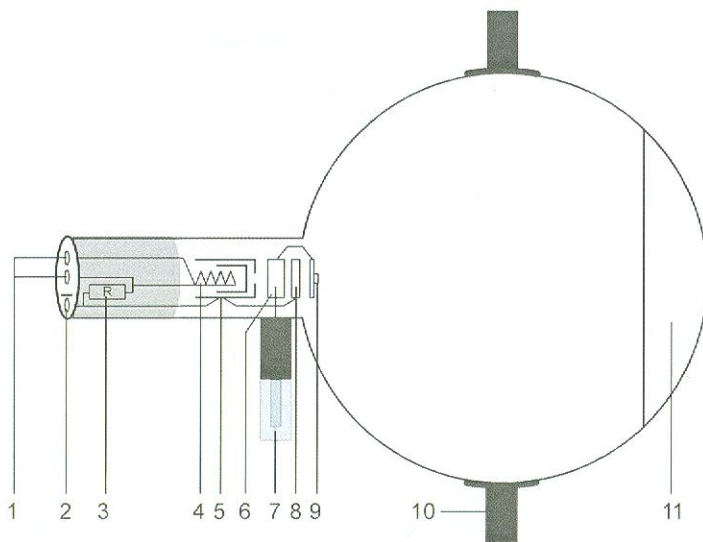

- 1 4-mm sockets for connecting heater supply
- 2 2-mm socket for connecting cathode
- 3 Internal resistor
- 4 Filament
- 5 Cathode
- 6 Anode
- 7 4-mm plug for connecting anode
- 8 Focussing electrode
- 9 Polycrystalline graphite grating
- 10 Boss
- 11 Fluorescent screen

1. Safety instructions

Hot cathode tubes are thin-walled, highly evacuated glass tubes. Treat them carefully as there is a risk of implosion.

- Do not subject the tube to mechanical stresses.
- Do not subject the connection leads to any tension.
- The tube may only be used with tube holder D (1008507).

If voltage or current is too high or the cathode is at the wrong temperature, it can lead to the tube becoming destroyed.

- Do not exceed the stated operating parameters.
- Only change circuit with power supply equipment switched off.
- Only exchange tubes with power supply equipment switched off.

When the tube is in operation, the stock of the tube may get hot.

- If necessary, allow the tube to cool before dismantling.

The compliance with the EC directive on electromagnetic compatibility is only guaranteed when using the recommended power supplies.

2. Description

The electron diffraction tube illustrates the wave nature of electrons by allowing observation of interference caused by a beam of electrons passing through a polycrystalline graphite target on a fluorescent screen (Debye-Scherrer diffraction). The wavelength of the electrons can be calculated for various anode voltages from the radius of the diffracted rings and the distance between the crystal layers in the graphite. The tube also confirms the de Broglie hypothesis.

The electron diffraction tube is a highly evacuated tube with an electron gun consisting of a pure tungsten heater filament and a cylindrical anode all contained in a clear glass bulb. The electrons emitted by the heated cathode are constrained to a narrow beam by an aperture and are then focussed by means of an electron-optical system. The resulting tight, monochromatic beam then passes through a micro-mesh nickel grating situated at the aperture of the gun. Onto this grid, a thin layer of polycrystalline graphitised carbon has been deposited by vapourisation. This layer affects the electrons in the beam much like a diffraction grating. The result of this diffraction is seen in the form of an image comprising two concentric rings that become visible on the fluorescent screen. A spot resulting from the undeflected electron beam continues to be visible at the centre of the rings.

A magnet is also supplied with the tube. This allows the direction of the electron beam to be changed, which may be necessary if the graphite target has slight damage as a result of the manufacturing process or due to later overheating.

3. Technical data

Filament voltage:	≤ 7.0 V AC/DC
Anode voltage:	0 – 5000 V DC
Anode current:	typ. 0.15 mA at 4000 V DC
Lattice constant of graphite:	$d_{10} = 0.213 \text{ nm}$ $d_{11} = 0.123 \text{ nm}$
Distance from graphite target to fluorescent screen:	$125 \pm 2 \text{ mm}$ approx.
Fluorescent screen:	100 mm dia. approx.
Glass bulb:	130 mm dia. approx.
Total length:	260 mm dia. approx.

4. Operation

To perform experiments using the electron diffraction tube, the following equipment is also required:

1 Tube holder D	1008507
1 High voltage power supply 5 kV (115 V, 50/60 Hz)	1003309
or	
1 High voltage power supply 5 kV (230 V, 50/60 Hz)	1003310
1 Analogue multimeter AM51	1003074

Additionally recommended:	
Protective Adapter, 3-Pole	1009960

4.1 Setting up the tube in the tube holder

- The tube should not be mounted or removed unless all power supplies are disconnected.
- Push the jaw clamp sliders on the stanchion of the tube holder right back so that the jaws open.
- Push the bosses of the tube into the jaws.
- Push the jaw clamps forward on the stanchions to secure the tube within the jaws.
- If necessary plug the protective adapter onto the connector sockets for the tube.

4.2 Removing tube from the tube holder

- To remove the tube, push the jaw clamps right back again and take the tube out of the jaws.

4.3 General instructions

The graphite foil on the diffraction grating is only a few layers of molecules thick and any current greater 0.2 mA can cause its destruction.

The internal resistor is there to prevent damage to the graphite foil.

The anode voltage and the graphite target itself should be monitored throughout the experiment. If the graphite target starts to glow or the emission current rises above 0.2 mA, the anode must immediately be disconnected from its power supply

If the diffraction rings are not satisfactorily visible, the electron beam can be redirected by a magnet so that it passes through an undamaged region of the target.

The electron beam can be focussed by applying a focussing voltage of 0 – 50 V DC (connected as in Fig. 2). This can be used to make the rings clearer and easier to observe at lower anode voltages.

5. Example experiment

- Set up the experiment as in Fig. 2. Connect the negative pole of the anode supply via the 2-mm socket.
- Apply the heater voltage and wait about 1 minute for the heater temperature to achieve thermal stability
- Apply an anode voltage of 4 kV.
- Determine the diameter D of the diffraction rings.

Two diffraction rings appear on the fluorescent screen centred on the undeflected beam in the middle. The two rings correspond to Bragg reflections from atoms in the layers of the graphite crystal lattice.

Changing the anode voltage causes the rings to change in diameter. Reducing the voltage makes the rings wider. This supports de Broglie's postulate that the wavelength increases as momentum is reduced.

a) Bragg equation: $\lambda = 2 \cdot d \cdot \sin \vartheta$

λ = wavelength of the electrones

ϑ = glancing angle of the diffraction ring

d = lattice plane spacing in graphite ✓

L = distance between sample and screen

D = diameter D of the diffraction ring ✓

R = radius of the diffraction ring ✓

$$\tan 2\vartheta = \frac{D}{2 \cdot L} \quad \lambda = d \cdot \frac{R}{L}$$

b) de-Broglie equation: $\lambda = \frac{h}{p}$

h = Planck's constant

p = momentum of the electrones

$$e \cdot U = \frac{p^2}{2 \cdot m} \quad \lambda = \frac{h}{\sqrt{2 \cdot m \cdot e \cdot U}}$$

m = electron mas, e = electron charge

gd500