

# Modeling the response of a thermistor\*

Muhammad Sabieh Anwar and Wajahat Sami Baig  
Centre for Experimental Physics Education  
LUMS School of Science and Engineering

January 6, 2026  
Version 2026-1

A thermistor is a semiconductor that is used to measure temperature. Its resistance depends on the temperature. The goal of the present experiment is to determine the resistance  $R$  as a function of temperature  $T$ . The experimental setup consists of a thermistor and a calibrated thermometer placed in a beaker filled with water. The beaker is placed on a heating mantle. A thermocouple that measures temperature is connected to a PhysTherm to record and transfer temperature data to a desktop using PhysLogger for further analysis. At the same time, the resistance of a thermistor is measured using an R-probe connected in a similar fashion to the thermocouple.

The resistance of a thermistors changes with temperature. The variation is usually modeled using the Steinhart-Hart equation,

$$\frac{1}{T} = A + B \ln(R) + C [\ln(R)]^3. \quad (1)$$

Heat the beaker of water while simulateneously measuring the resistance and the temperature using the two sensors provided. Analyze the relationship between temperature and resistance and determine the appropriate method to find coefficients  $A$ ,  $B$ , and  $C$ . Is the Steinhart-Hart a good model to work with?

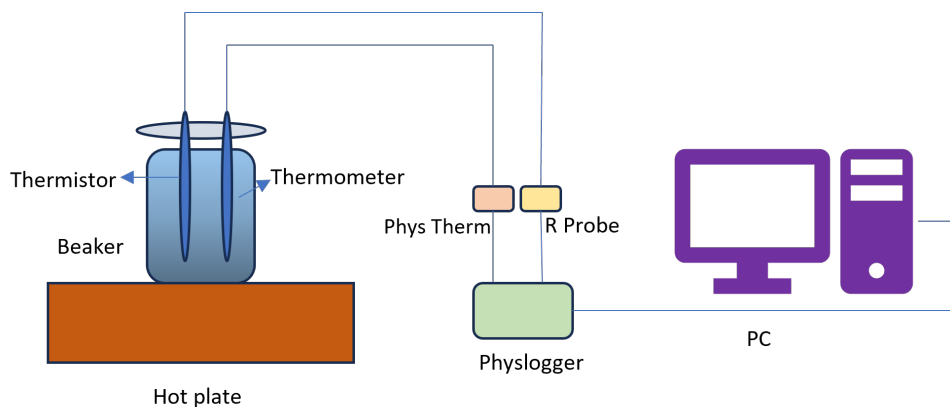

Figure 1: Experimental design of the setup.

---

\*No part of this document can be re-used without explicit permission from the author(s).