

## Chaos in Nature قدرت میں انتشار

Jamal Liaqat and Muhammad Sabieh Anwar

May 6, 2026

In our daily lives, we get the chance to observe many extraordinarily complex phenomena. Take the weather, for example. The sky is clear in the morning, then suddenly clouds gather, a light drizzle begins, followed by strong winds. The sound of raindrops falling on a tin roof may come on a regular rhythm, and sometimes create a chaotic melody in an agitated.

روزمرہ زندگی میں ہمیں کئی بار انتہائی پیچیدہ مناظر کا مشاہدہ کرنے کا موقع ملتا ہے۔ موسم ہی کو دیکھ لیں۔ صبح آسمان صاف ہے، اچانک بادل چھا جاتے ہیں، ریم جھم بارش اور پھر تیز ہواؤں کا سلسلہ شروع ہو جاتا ہے۔ ٹین کی چھت پہ گرنے والے قطروں کی آواز کبھی باقاعدہ برابر وقفوں سے آتی ہے اور کبھی ایک ہیجانی انداز میں ترنم برپا کر دیتی ہے۔



Similarly, if you observe the human heart-beat carefully, it is not completely regular, the interval from one beat to the next keeps changing. This irregularity is in fact a sign of a healthy heart. Even in good music, turbulence and irregularity are key characteristics.

انسانی جسم میں دل کی دھڑکن کا اگر غور سے مشاہدہ کریں، تو وہ مکمل طور پر باقاعدہ نہیں، بلکہ اس میں ایک دھڑک سے لے کے دوسری دھڑک تک وقفہ بدلتا رہتا ہے۔ یہ بے قاعدگی دراصل دل کی صحت کی علامت ہے۔

In this experiment, we will try to observe and understand signals of this very nature. Nonlinear and chaotic phenomena are what make science truly fascinating and are a fundamental characteristic of our natural world.

کانوں کو بھلی لگنے والی موسیقی میں بھی تلاطم اور  
بے قاعدگی نظر آتی ہے۔

اس تجربے میں ہم اسی نوع کے پیچیدہ سگنلز کو دیکھنے اور  
سمجھنے کی کوشش کریں گے۔ غیر خطی اور ہیجان مآثرے  
در اصل سائنس کو دلچسپ بناتے ہیں اور ہماری فطرت کا  
اہم راز ہیں۔

Chaos is all around us, even if we do not always notice it. You can see it in the swirling motion of smoke, the irregular dripping of a tap, the flicker of a candle flame, in weather patterns and even in secure communication. These systems may look random, but surprisingly, many of them are not random at all.

Chaos is a special type of behavior that appears in nonlinear systems. It is deterministic, meaning it follows exact mathematical rules. However, it is extremely sensitive to initial conditions. A very small change at the beginning can lead to a completely different outcome later. This is often called the sensitive dependence on initial conditions.



In the current Phenomenon Lab, you will explore the meaning of chaos and how it fundamentally differs from randomness. You will learn how to identify chaotic behavior through the use of plots and diagrams, and understand the key visual signatures associated with such systems. Furthermore, the experiment will guide you through the principles behind generating chaos using electronic circuits, providing both a conceptual understanding and practical insight. By the end, you will see how simple electronic components can create beautifully complex and unpredictable behaviors which are chaotic.

سچھے صفحے پہ نظر آنے والی  
تتلی برازیل میں اپنے پروں کو  
پھڑپھڑائے تو پاکستان میں بگولہ  
بن سکتا ہے۔ یہی انتشار کی بنیادی  
خاصیت ہے۔ ایک چھوٹا سا محرک  
بڑے طوفان کو جنم دے سکتا ہے۔

## 1 Building up the ingredients of chaos

### 1.1 Non-deterministic random processes

Random processes are a common phenomenon. Suppose you are standing next to a highway. A car passes in front of you and you note down the times of their passage. Their seems to be no pattern on the timing of these fleeting cars. You calculate the time intervals between passing cars. As a result you may get a sequence like this,

$$[24.1 \ 15.5 \ 56.7 \ 10.9 \ 33.6 \ \dots](s) \quad (1)$$

which indicates a random process. There is no way you can *determine* or predict when the next car passes.

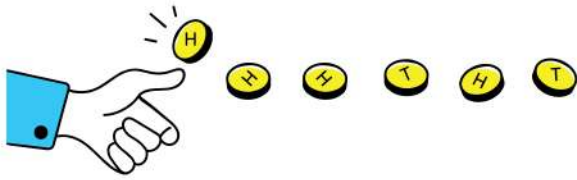

Similarly, if you toss a coin over and over again, you may get a sequence of tails and heads,

$$[HHTHTTHTHHTTTTHT\dots] \quad (2)$$

and there is no way to say precisely what the next outcome would be. Each run is independent and picks up either  $H$  or  $T$  with almost equal probability.

## 1.2 Probability distributions

In the coin toss example, the probability for each of  $H$  or  $T$  is  $1/2$  and this can be presented through a probability distribution, as shown in Fig. 1(a). Simultaneously, if we have the possibility of choosing a number between 0 and 1 and there is equal likelihood of choosing any number whatsoever in this range, we can draw another probability distribution. This is shown as a continuous straight line extending between 0 and 1, as shown in Fig. 1(b).

For example, randomly selecting ten numbers from this probability distribution yielded us a sequence of numbers whose first six entries were

$$[0.904 \quad 0.584 \quad 0.571 \quad 0.944 \quad 0.726 \quad 0.068\dots]. \quad (3)$$

You cannot tell what the fifth number would be if you already knew the fourth, and you wouldn't know the sixth if you knew the fifth, *ad infinitum*. This is what we mean by a nondeterministic, or a random process.

**[Q 1]**. Try to plot 10 random numbers between 0 and 1. Can you predict the eleventh number? Plot the 10 random numbers again. Is the plot still same?

**[Q 2]**. Plot 100 random numbers between 0 and 1.

You will find that your plots will look like a messy jumble with no order whatsoever. This is true for a nondeterministic random process, even though the uniform probability distribution is a neat straight line.

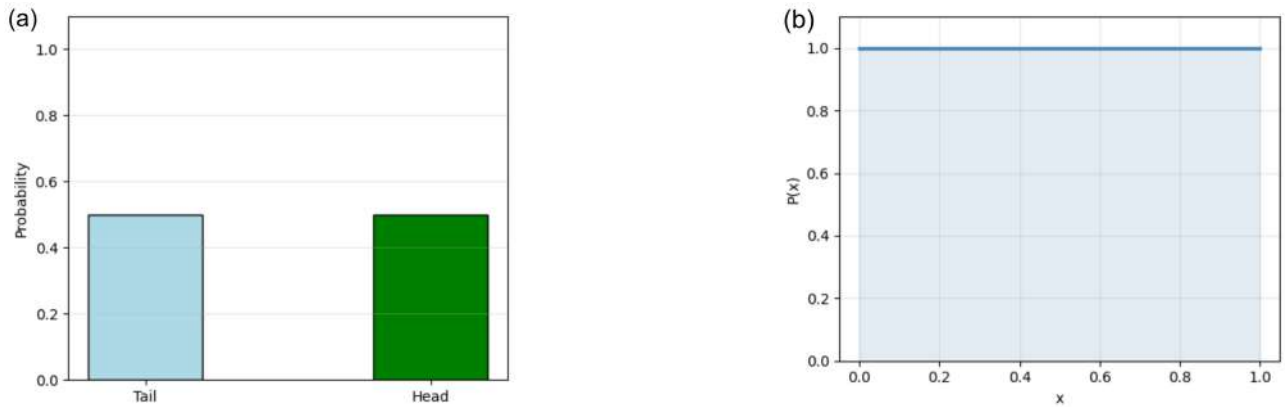

Figure 1: Probability distributions (a) for a tossed coin and (b) for choosing a number between 0 and 1.

### 1.3 Deterministic processes

Let's look at another process that looks random, at least from its appearance! This time let's work with an equation that describes a natural phenomenon such as how a disease spreads, bacteria multiply or how people adopt new technology e.g. electric cars. The equation we propose is called the logistic map and is given by,

$$x_{N+1} = rx_N(1 - x_N). \quad (4)$$

Here,  $x_N$  represents the value of a variable  $x$  at iteration  $N$ , and  $r$  is a control parameter known as the growth rate. The variable  $x_N$  lies between 0 and 1. The variable can depict the number of infected people at a time, size of a bacterial colony or the number of  $x$  people in a population who own smart electric vehicles.

We fix  $r = 3.9$ , We start with a value of  $x_0 = 0.5$ . We insert these values into Eq. (4) and obtain  $x_1 = 0.975$ . In the next step, running the equation again yields  $x_2 = 0.095$  and after a few runs, we start building up a sequence of numbers,

$$[0.500 \quad 0.095 \quad 0.335 \quad 0.869 \quad 0.443 \quad 0.962 \dots]. \quad (5)$$

We can plot these numbers and obtain a graph similar to Fig. 2(b). This looks all jumbled up and noisy, and not much different in its character from the nondeterministic sequence of random numbers (generated from the probability distribution Fig. 1(b)) shown in Fig. 2(a) plot, but surely we know that our process is completely deterministic and dictated by Eq. (4). For example knowing  $x_{20} = 0.328$  determines  $x_{21} = 0.859$ ,  $x_{22} = 0.471$  and all  $x_N$ 's that follow. The variable is deterministic even though the visual plots for nondeterministic random and deterministic processes look almost similar.

**[Q 3]**. Try making the table of 10 values using the logistic map (Eq. (4)) and plot them. Can you predict the next value? Now, repeat the procedure and plot 1000 points, can you predict the 1001<sup>th</sup> value knowing the 1000<sup>th</sup> value?

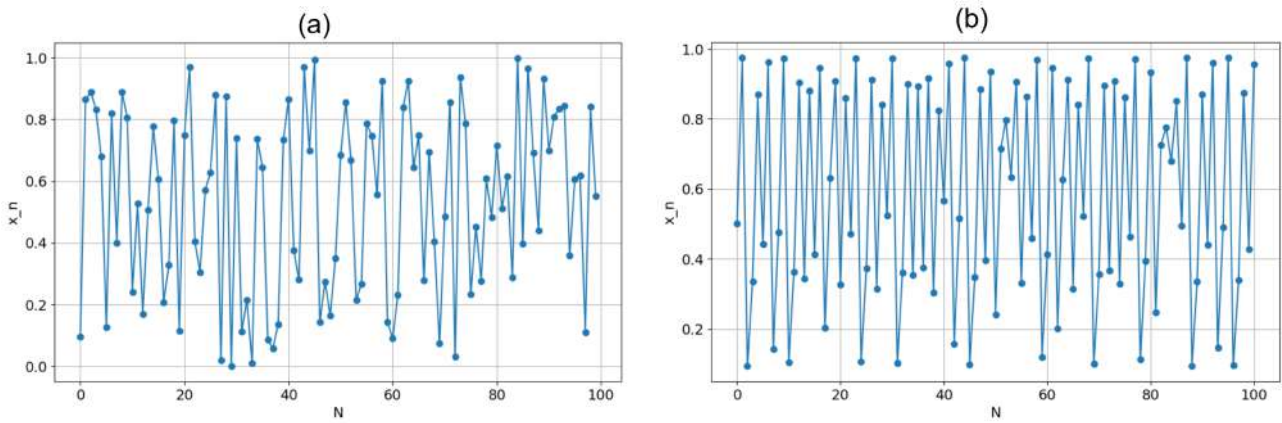

Figure 2: Comparison between (a) randomly generated data and (b) deterministic data that is generated from the logistic map.

The deterministic logistic map (with  $r = 3.9$ ) represents a process called “chaos”. We will shortly describe this phenomenon in a bit more detail. For now, let’s try to vary the parameter  $r$ .

**[Q 4]**. With  $r = 1.5$  and starting with  $x_0 = 0.5$ , plot the sequence of points. What if  $r = 3.0$ , 3.5 and 4.5? You may like to remove the transients from the early part of the graph to clearly see the behavior of the sequence of values. We expect that you will obtain a series of plots similar to those shown in Fig. 3.

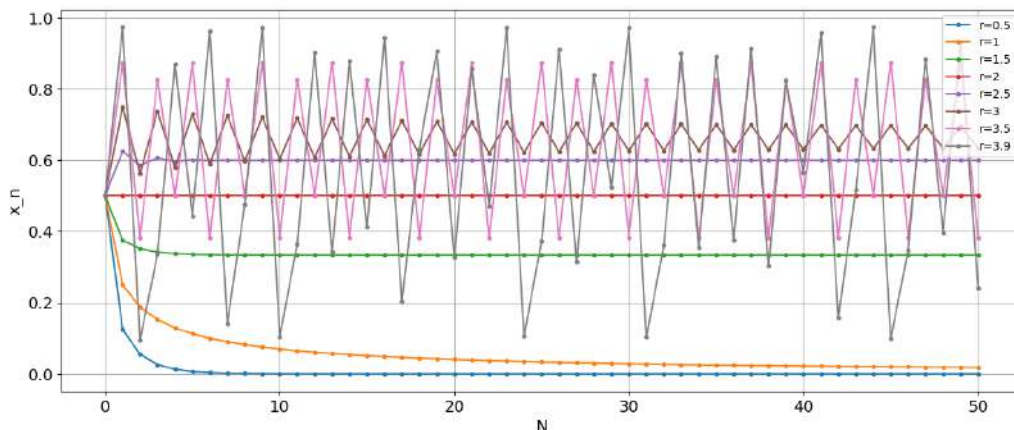

Figure 3: Impact of varying the parameter  $r$  on the time series of the logistic map.

Deterministic chaos and randomness data look alike, how do we distinguish between them?

## 1.4 The phase portrait

You’ve seen that when plotted versus time, nondeterministic random and deterministic chaotic signals may look similar. How can one tell the difference? As we try to answer this question, we will also begin to probe the meaning of “chaos” a bit deeper.

The chaotic signal is deterministic, a value will determine its next. This is not true for a random variable, which is independent on every trial resets itself every instance. Therefore, if we have a means to plot a value and its next value,  $x_N$  and  $x_{N+1}$ , and plot all such pairs in the sequence,

we expect that the random variable shows no interesting pattern it is still a smudge of points. However, for the deterministic chaos signal, this plot, which is now called the phase portrait, shows a regular streak of points, an “orbit”. A regular phase portrait, therefore, is one means to identify deterministic chaos.

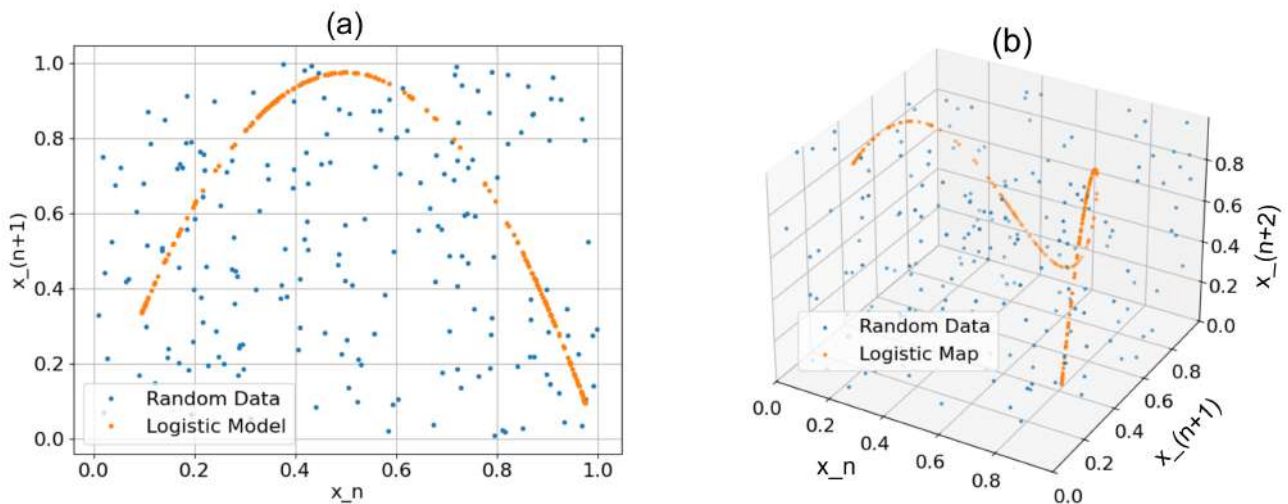

Figure 4: Phase plot of random data and the logistic map in (a) 2D and (b) 3D, plotted against the backdrop of random data.

[Q 5]. Make phase plots of  $x_{N+1}$  versus  $x_N$  for both random data and logistic model. How are these patterns different?

[Q 6]. Make a three-dimensional plot which takes three consecutive points  $x_{N+2}$ ,  $x_{N+1}$  and  $x_N$  instead of two points? Your data may look similar to what is shown in Fig. 4(b).

## 1.5 Sensitivity to initial conditions

Another thing separating chaos from randomness is to check its dependency on initial conditions. Two nearly identical starting points can evolve into completely different trajectories over time, a behavior that is unique to chaos.

For a nondeterministic random process, there is no divergence. In this case, initial conditions do not matter as each trial is independent. These two kinds of behaviors are shown in Fig. 5 where a non-deterministic random process (a) is shown to be totally independent of initial conditions. Each initial condition produces a random outcome which in no way is determined by what the initial condition is. For deterministic chaos, on the other hand, as Fig. 5(b) indicates, different initial conditions lead to similar plots which overlap in the beginning, but as the time progresses and  $N$  increases, the plots start losing their overlap and begin to diverge.

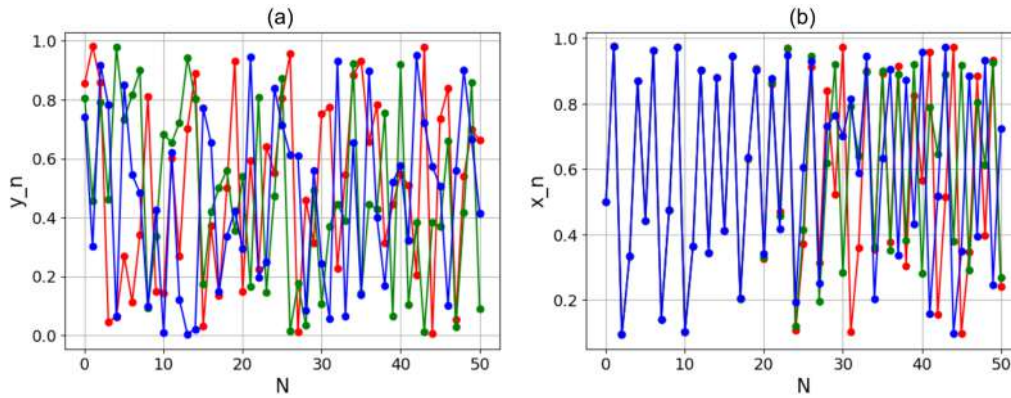

Figure 5: The different lines in the graph explain the dependency of (a) randomness and (b) deterministic model on initial conditions.

In fact the difference between trajectories keeps on building up. Mathematically we can say that the difference grows exponentially as  $e^{\lambda t}$  where  $\lambda$  is called a Lyapunov exponent. This behaviour is shown in Fig. 6 and probed further in Q7. This sensitive dependence on initial conditions makes the chaotic system extremely erratic and it becomes hard to predict how the system will behave. Consider why weather patterns can change all of a sudden and may deviate wildly from the meteorologist department's predictions.

**[Q 7]**. Try to plot two time series using the logistic map Eq. 4, but each time employing slightly different initial conditions at  $r = 4$  and  $N = [1, 2, 3, 4, 5, 6, 7, 8]$ . Now, take the absolute difference at each discrete point and plot the differences. What is the effect of slightly different initial conditions on the series? Can you estimate the Lyapunov exponent for this process?

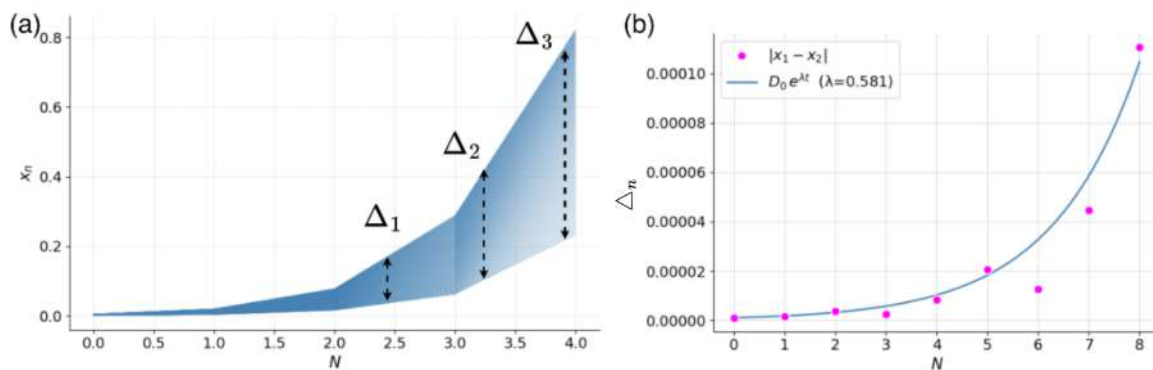

Figure 6: In part, (a) shows 100 orbits with slightly different initial conditions indicating that the series are pushed apart with time and (b) the divergence graph for the difference between the two orbits.

## 1.6 Path to chaos

A system can be well-behaved and periodic but changing some parameter can turn it into a chaotic signal. A case in point is the logistic map, Eq. (4). Here  $r$  is the parameter of interest and its value determines what kind of sequence we obtain. The sequences are already shown in Fig. 3. For smaller values of  $r$ , the series converges to some constant value; as  $r$  increases we obtain a periodic system; followed by a period-2 system, and eventually chaos. This progression is conceptually illustrated in Fig. 7. The route to chaos therefore is both interesting and systematic.

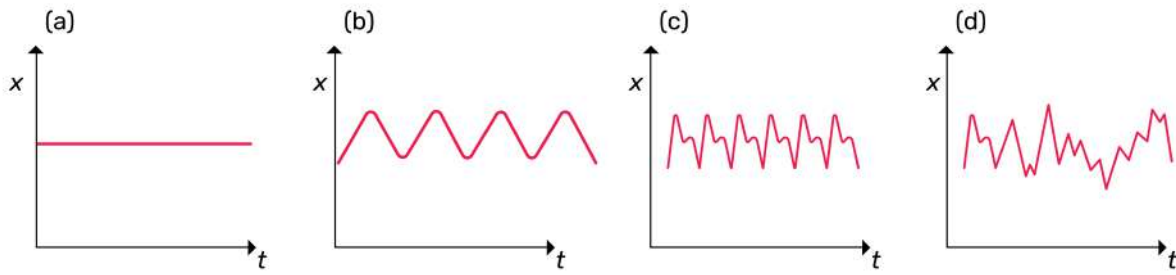

Figure 7: The graphs show the path to chaos (a) to (d) depending on the control parameter  $r$ .

We can also describe this progression through a bifurcation diagram. A bifurcation diagram shows the long-term behavior of a system as a control parameter (such as  $r$  in the logistic map) is gradually changed. As the parameter increases, the system may move from stability to oscillation, split into multiple oscillations (period doubling), and eventually enter the chaotic regime. Furthermore, if you zoom into the chaotic region, you will notice self-similar patterns. This repeating structure is a signature of fractal behavior. We put off a discussion of fractals to another Phenomenon Lab.

**[Q 8]**. To distinguish periodic behavior from chaos, plot the orbit values with respect to the control parameter  $r$ . You will obtain a diagram similar to what is shown in Fig. 8.

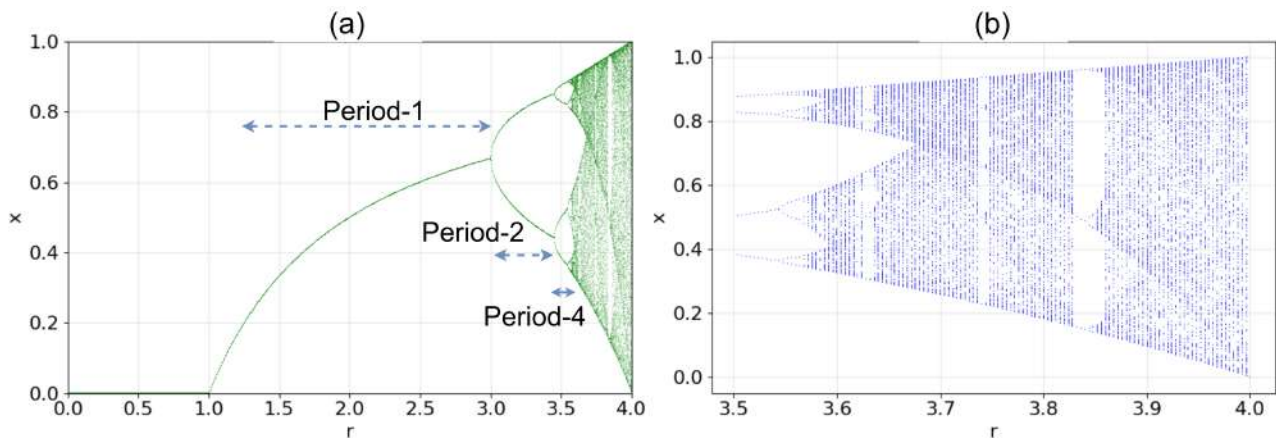

Figure 8: The figure shows: (a) bifurcation diagram of logistic map and (b) zoomed into view of chaotic regime displaying self similar pattern. Note in these diagrams the values of  $x$  are plotted on y-axis for a given  $r$ . The region between  $r = 1.0$  and  $r = 3.0$  shows a periodic plot; between 3 and 3.449, we see period-2; between 3.449 and 3.544 we observe period-4; followed by chaos.

**[Q 9]**. Can you reproduce the bifurcation diagram shown in Fig. 8.



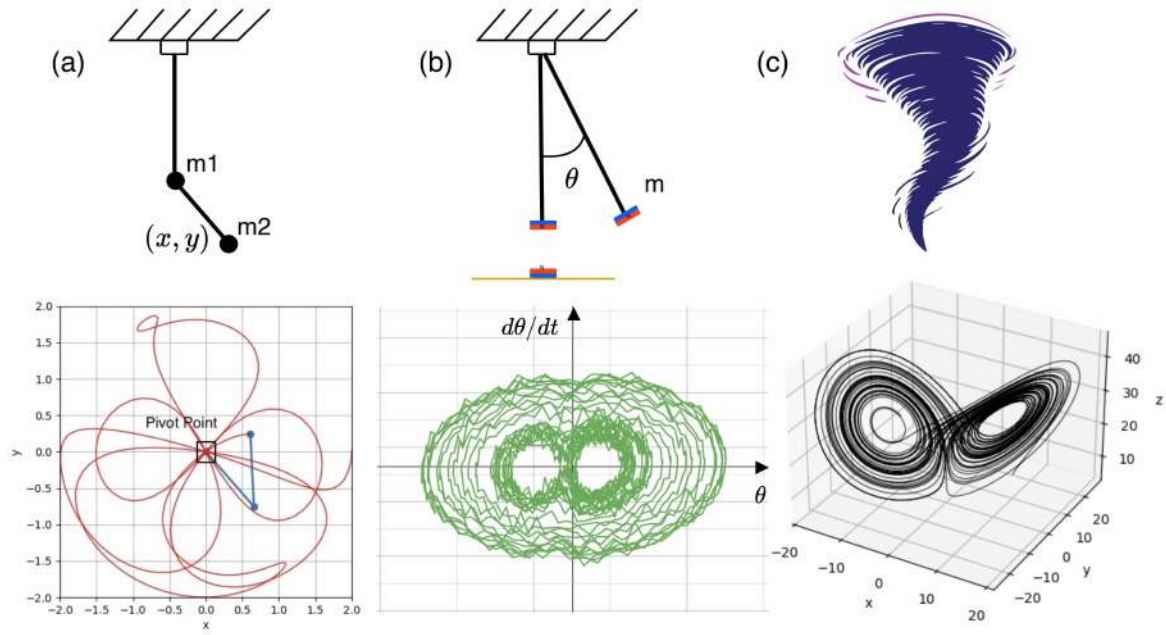

Figure 9: Some example graphs for chaos using mathematical models, (a) trace for lower tip of double rod pendulum, (b) plot of derivative of angle of a magnetic pendulum, (c) the Lorenz model which is commonly used to illustrate weather prediction in phase domain.

## 2.1 The Chua Circuit

The Chua circuit is a simple electronic system that demonstrates chaotic behavior in a tangible way. Unlike ordinary oscillators, the voltages it produces never repeats, forming complex and unpredictable waveforms. Though simple in design, the chaotic circuit produces complex, unpredictable behavior, showing bifurcations, limit cycles, multi-period oscillations, and chaos.

The Chua circuit can be realized using basic linear components like capacitors ( $C_1$  and  $C_2$ ), resistors ( $R$ ), inductors ( $L$ ) and one non-linear element ( $N_R$ ).

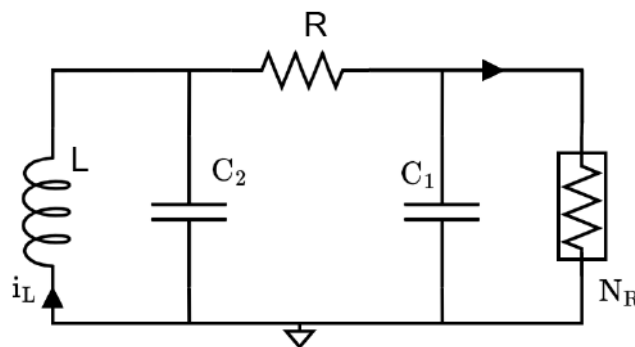

Figure 10: Chua's circuit consists of a linear inductor  $L$ , a linear resistor  $R$ , two linear capacitors  $C_1$  and  $C_2$  and a nonlinear resistor  $N_R$ .

Analyzing the circuit using Kirchhoff's circuit laws, the dynamics of Chua's circuit can be accurately modeled by means of a system of three nonlinear ordinary differential equations (ODEs) in the variables  $V_{C_1}$ ,  $V_{C_2}$ , and  $i_L$ , which represent the voltages across two linear capacitors  $C_1$  and  $C_2$  and the electric current in a linear inductor ( $L$ ) respectively. These nonlinear

equations are:

$$\begin{aligned}\frac{dV_{C_1}}{dt} &= \alpha (V_{C_2} - V_{C_1} - f(V_{C_1})), \\ \frac{dV_{C_2}}{dt} &= V_{C_1} - V_{C_2} + i_L, \text{ and} \\ \frac{di_L}{dt} &= -\beta V_{C_2},\end{aligned}\tag{6}$$

where  $\alpha$  and  $\beta$  are parameters. If these ODEs are solved for a certain time and then plotted, as shown in Fig.11, chaos can be visualized. We have done this for you already in the provided Jupyter Notebook.

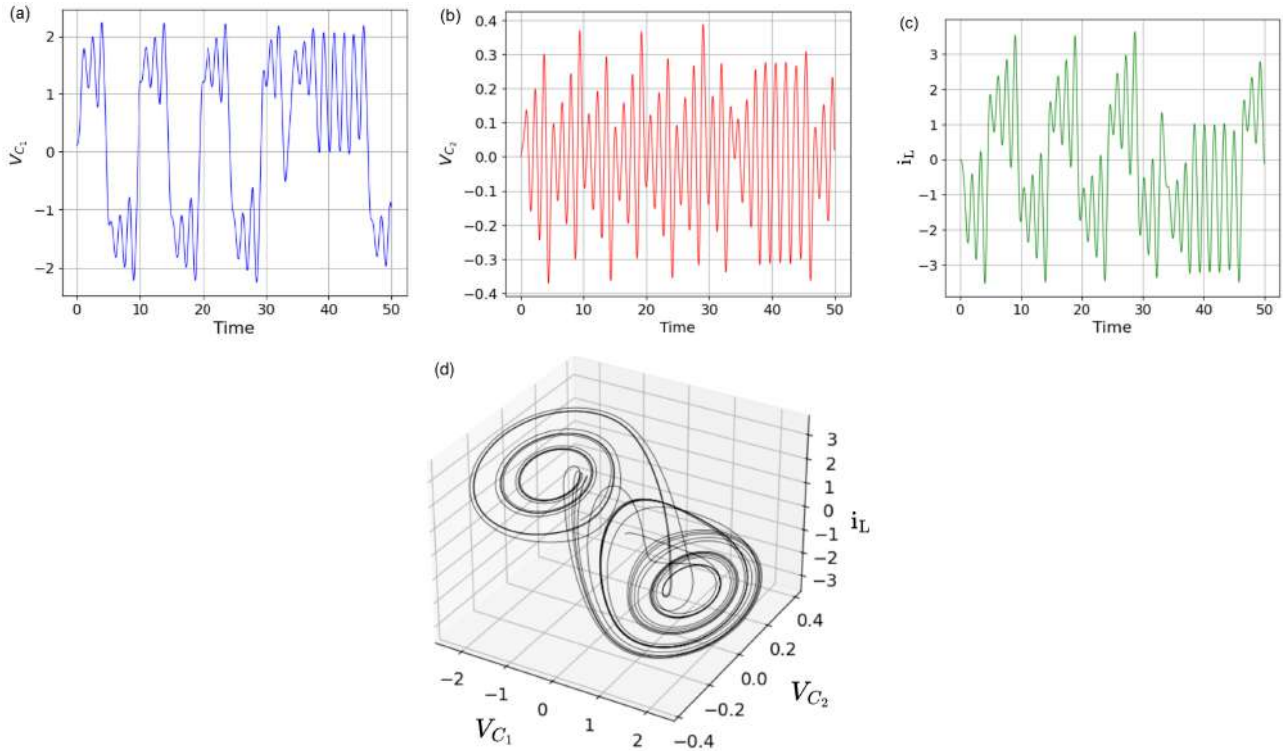

Figure 11: Simulation results for the Chua Circuit: (a, b and c) graphs show plots of  $V_{C_1}$ ,  $V_{C_2}$  and  $i_L$  with respect to time and (d) is the 3D graph for all three variables plotted with respect to each other, as phase potrait. These plots were obtained with  $\alpha = 15.6$ ,  $\beta = 28$  and initial values  $V_{C_1} = 0.1$ ,  $V_{C_2} = 0$  and  $i_L = 0$ .

## 2.2 The Setup

In order to observe chaos and obtain a phase potrait similar to Fig. 11, all you need is Qosain Scientific’s circuital chaos generator and an oscilloscope. To get started with chaos generator circuit, follow these steps:

- Plug in the AC supply to Qosain Scientific’s chaos generator device.
- Connect Two BNC outputs to inputs of the oscilloscope as shown in Fig. 12.
- Adjust the front-end knob to tune the system behavior.
- Chaos appears at the correct knob position and the double-scroll attractor can be visualized in the X–Y mode of the oscilloscope.

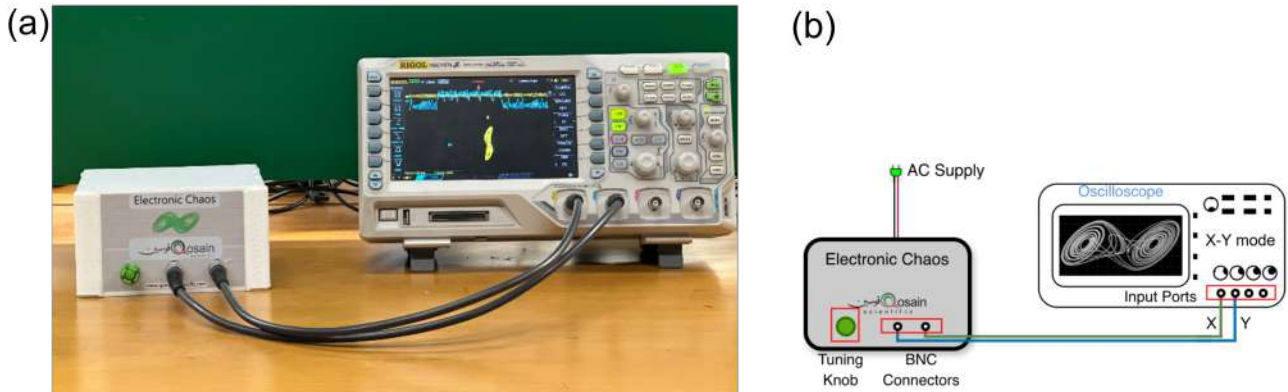

Figure 12: (a) Real photograph, and (b) connection diagram of Qosain Scientific's Chua Circuit.

### 2.2.1 Working

The Chua Circuit device generates chaotic oscillations using basic electrical components and an effective inductance. When powered through the AC supply, the circuit becomes active and the user can control its behavior using a single variable resistor knob. Adjusting this knob changes the system's frequency and operating conditions, allowing the circuit to transition from regular oscillations into the chaotic regime. The two BNC outputs provide the key voltages of the circuit, which can be observed on an oscilloscope to view the characteristic double-scroll effect. The circuit in fact provides a physical implementation of the system of Eq. 6.

[Q 10]. What is an attractor? Describe in your own words what the double-scroll attractor represents in the context of the Chua Circuit.

[Q 11]. As you slowly adjust the resistor knob, describe the changes you observe in the oscilloscope output. Does the signal transition gradually or abruptly from periodic to chaotic behavior?

[Q 12]. What happens to the attractor if you turn the knob too far in either direction?

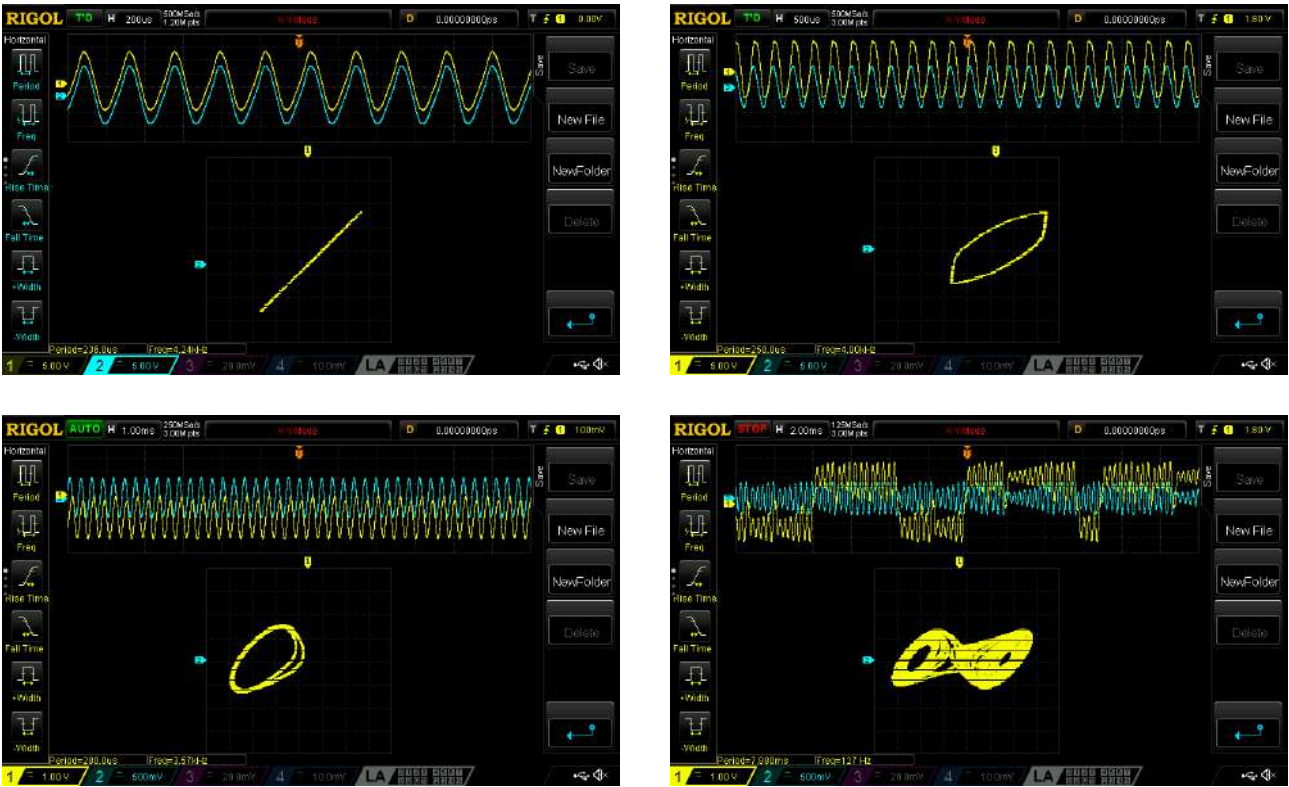

Figure 13: Some results from the Chua circuit displayed on the oscilloscope screen. The plots were generated as the knob was rotated, showing progression from a linear pattern to chaos. The kind of phase diagram that appears when tuning has been optimized, is called a strange attractor.



[Q 13]. If you return the knob to the same position as before, do you observe the exact same chaotic pattern? What does your observation tell you about the sensitivity of the system to its operating conditions?

[Q 14]. The Chua circuit uses a nonlinear element to produce chaos. Why is nonlinearity essential? Could a purely linear circuit (resistors, capacitors, inductors only) produce chaotic behavior?

[Q 15]. Based on your observations, how would you explain chaos in electronics to someone with no physics background? Use one analogy from daily life.

## References

- [1] Kennedy, M. P. (1992). Robust op amp realization of Chua's circuit. *Frequenz*, 46(3), 66–80.

